

Este es el producto que ha comprado!
This is the product you have purchased!
Esse é o produto que você adquiriu!
Voici le produit que vous avez acheté!

Ref. 1160

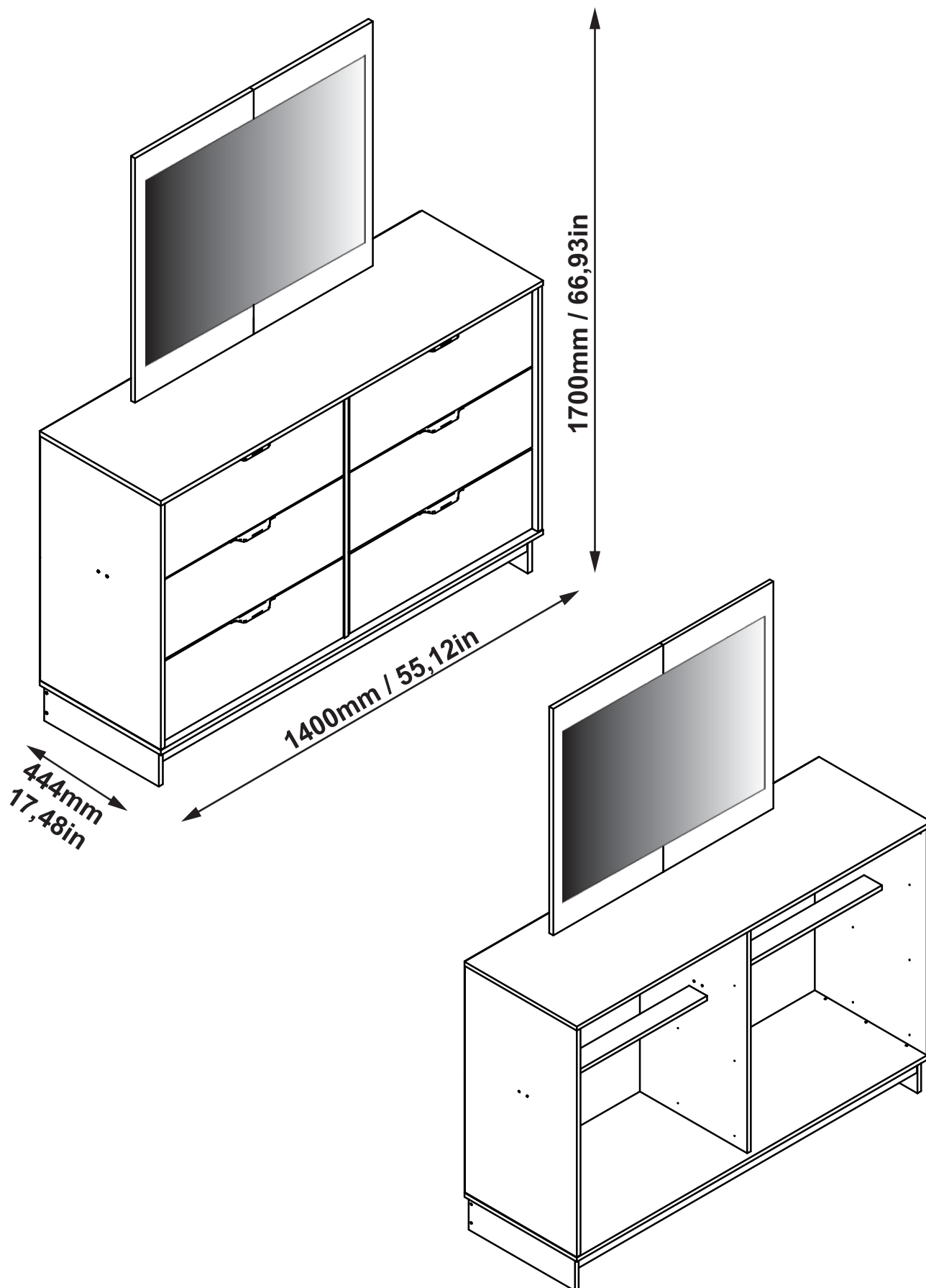

RECOMENDACIONES PARA EL USO Y CUIDADO DEL PRODUCTO
RECOMMENDATIONS FOR THE USE AND CARE OF THE PRODUCT
RECOMENDAÇÕES DE USO E CUIDADOS COM O PRODUTO
RECOMMANDATIONS POUR L'UTILISATION ET L'ENTRETIEN DU PRODUIT



ES: Lea cuidadosamente el manual y siga en el orden indicado las instrucciones de ensamble.
EN: Read the manual carefully and follow the assembly instructions in the order listed.
PT: Leia o manual com atenção e siga as instruções de montagem na ordem listada.
FR: Lisez attentivement le manuel et suivez les instructions de montage dans l'ordre indiqué.



ES: No pinte ni use elementos abrasivos para limpiar el mueble.
EN: Do not paint or use abrasive items to clean the furniture.
PT: Não pinte ou use itens abrasivos para limpar o móvel.
FR: Ne pas peindre ni utiliser d'objets abrasifs pour nettoyer l'armoire.



ES: No exponga el mueble al calor ni a la humedad.
EN: Do not expose the furniture to heat or humidity.
PT: Não exponha a mobília ao calor ou umidade.
FR: N'exposez pas le meuble à la chaleur ou à l'humidité.



ES: - No arraste el mueble, esto puede causar daños en las piezas.
 - Para desplazar el mueble asegúrese de moverlo cuando este vacío sin objetos.
 - Siempre solicite ayuda a otra persona para moverlo.
EN: - Do not drag the furniture, this can cause damage to the pieces.
 - To move the furniture be sure to move it when it is empty without objects.
 - Always ask someone else to help you move it.
PT: - Não arraste o móvel, pois isso pode causar danos às peças.
 - Para mover o móvel certifique-se de movê-lo quando estiver vazio e sem objetos.
 - Sempre peça a outra pessoa para ajudá-lo a movê-lo.
FR: - Ne traînez pas le meuble, cela peut endommager les pièces.
 - Pour déplacer le meuble veillez à le déplacer lorsqu'il est vide sans objets.
 - Demandez toujours à quelqu'un d'autre de vous aider à le déplacer.

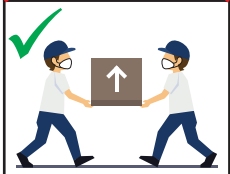

PT: - Não arraste o móvel, pois isso pode causar danos às peças.
 - Para mover o móvel certifique-se de movê-lo quando estiver vazio e sem objetos.
 - Sempre peça a outra pessoa para ajudá-lo a movê-lo.
FR: - Ne traînez pas le meuble, cela peut endommager les pièces.
 - Pour déplacer le meuble veillez à le déplacer lorsqu'il est vide sans objets.
 - Demandez toujours à quelqu'un d'autre de vous aider à le déplacer.



ES: Limpia regularmente la madera con un paño de microfibra para que no se acumule el polvo y así evitar que el mueble pierda su brillo.
EN: Regularly clean the wood with a microfiber cloth so that dust does not accumulate and thus prevent the furniture from losing its shine.
PT: Limpe regularmente a madeira com um pano de microfibra para que o pó não se acumule e evite que o móvel perca o brilho.
FR: Nettoyez régulièrement le bois avec un chiffon microfibre afin que la poussière ne s'accumule pas et ainsi éviter que le meuble ne perde de son éclat.



ES: No utilice papel periódico para brillar vidrios y/o espejos, esto los puede rayar. Es recomendable utilizar paños que no dejen pelusa.
EN: Do not use newspaper to shine glass and / or mirrors, this can scratch them. It is recommended to use lint-free cloths.
PT: Não use jornal para lustrear vidros e / ou espelhos, pois podem riscá-los. É aconselhável usar panos sem fiapos.
FR: N'utilisez pas de papier journal pour faire briller le verre et/ou les miroirs, cela peut les rayer. Il est conseillé d'utiliser des chiffons non pelucheux.



ES: Evita que el agua entre en contacto con las partes de metal, ya que puede provocar manchas y óxido.
EN: Avoid getting water on metal parts as it can cause stains and rust.
PT: Evite molhar as peças de metal, pois pode causar manchas e ferrugem.
FR: Évitez de mettre de l'eau sur les pièces métalliques car cela peut causer des taches et de la rouille.



ES: Ubica tus productos en una superficie lisa y plana. Utilice una protección entre el mueble y el piso.
EN: Place your products on a smooth, flat surface. Use a protection between the furniture and the floor.
PT: Coloque seus produtos em uma superfície lisa e plana. Use uma proteção entre a mobília e o chão.
FR: Placez vos produits sur une surface lisse et plane. Utilisez une protection entre le meuble et le sol.

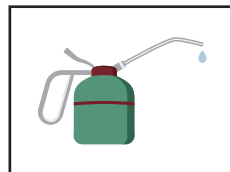

ES: Se recomienda lubricar cada 3 meses rieles, correderas, bisagras y rodachinas.
EN: It is recommended to lubricate the rails, runners, hinges and castors every 3 months.
PT: Recomenda-se a lubrificação de trilhos, corredeiras, dobradiças e rodízios a cada 3 meses.
FR: Il est recommandé de lubrifier les rails, glissières, charnières et roulettes tous les 3 mois.



ES: No utilizar las gavetas como escaleras ni permitir que los niños se cuelguen de las puertas.
EN: Do not use drawers as ladders or allow children to hang from doors.
PT: Não use gavetas como escadas, nem permita que crianças se pendurem nas portas.
FR: N'utilisez pas les tiroirs comme échelles et ne laissez pas les enfants se suspendre aux portes.



ES: Evita que el trapeador o elementos similares entren en contacto con tus muebles ya que esto puede deteriorarlos.
EN: Avoid that the mop or similar elements come into contact with your furniture as this can deteriorate them.
PT: Evite que a esfregona ou elementos semelhantes entrem em contacto com os seus móveis, pois pode deteriorá-los.
FR: Évitez que la serpillière ou des éléments similaires entrent en contact avec vos meubles car cela peut les détériorer.



ES: Mantén alejado objetos puntiagudos como tijeras, llaves o cuchillos. Éstos pueden causar cortes y/o rayones.
EN: Keep sharp objects like scissors, keys, or knives away. These can cause cuts and / or scratches.
PT: Mantenha objetos pontiagudos como tesouras, chaves ou facas longe. Isso pode causar cortes e / ou arranhões.
FR: Gardez les objets pointus comme des ciseaux, des clés ou des couteaux à distance. Ceux-ci peuvent provoquer des coupures et/ou des rayures.

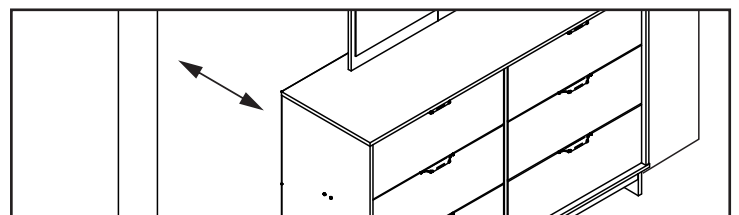

ES: Se recomienda separar de la pared tus productos para que estos puedan tener una circulación de aire natural.
EN: It is recommended to separate your products from the wall so that they can have a natural air circulation.
PT: Recomenda-se separar seus produtos da parede para que tenham uma circulação natural de ar.
FR: Il est recommandé de séparer vos produits du mur afin qu'ils puissent avoir une circulation d'air naturelle.

Consejos de Conservación y Pesos soportados

Conservation Tips and Supported Weights

Dicas de Conservação e Pesos Suportados

Conseils d'entretien et Poids soutenus

ES: 1. No debe utilizarse en la limpieza, abrasivos como lana de acero, alcohol, limón, o productos corrosivos que puedan rayar o quitar la película en los muebles.

2. Cuando la limpieza de muebles en general, napa y formica, deben utilizarse un paño ligeramente humedecido y jabón suave.

3. Para mover el mueble, es importante que este se eleve desde el suelo, debido a que el arrastre puede causar daño estructural.

4. No deje el mueble en exposición a la intemperie.

EN: 1. Do not use abrasive products to clean such as steel wool, alcohol, vinegar, lemon, scouring powder, or corrosive products which can scratch or peel off the protective film of the furniture.

2. The best way to clean your furniture is to use a slightly moistened cloth with a mild soap.

3. To move the furniture assembled, it is important that it is lifted off the ground, because the drag it can cause structural damage.

4. Do not leave your furniture in weather exposure.

PT: 1. Não utilizar na limpeza produtos abrasivos tais como: palha de aço, álcool, vinagre, limão, saponáceo ou produtos corrosivos que possam riscar ou descolar a película protetora dos móveis.

2. Na limpeza de móveis em geral, nappas e fórmicas, deve ser utilizado um pano levemente umedecido e sabão neutro.

3. Para a movimentação do móvel, é importante que este seja levantado do chão, pois ao arrastá-lo pode causar avarias estruturais.

4. Não deixe o móvel em exposição a intempéries.

FR: 1. Ne pas utiliser de produits abrasifs dans le nettoyage, tels que: laine d'acier, alcool, vinaigre, citron, poudre à récurer ou autres produits corrosifs pouvant rayer ou faire décoller la pellicule protectrice des meubles.

2. Pour le nettoyage du meuble, il est recommandé d'utiliser un chiffon humide et du savon neutre.

3. Pour déplacer le meuble, il est important de le soulever du sol car le tirer pourrait causer des dommages dans sa structure.

4. Ne pas exposer le meuble aux intempéries.

ES: Por favor, preste atención a los pesos máximos admitidos por cada compartimento del producto. Tenga cuidado de no exceder estos pesos, con el fin de garantizar la calidad y durabilidad del producto. Es importante recordar que los pesos muestran en caso de ser DISTRIBUIDA en toda el área de la plataforma.

EN: Please pay attention to the maximum weights supported by each compartment product. Be careful not to exceed these weights, in order to ensure the quality and durability of the product. It is important to remember also that the weights shown should be DISTRIBUTED throughout the area of the shelf.

PT: Por favor, preste atenção aos pesos máximos suportados por cada compartimento do produto. Cuide para não exceder esses pesos, afim de garantir a qualidade e a durabilidade do mesmo. É importante lembrar também que, os pesos mostrados devem ser DISTRIBUÍDOS ao longo de toda a área da peça.

FR: Veuillez faire attention aux poids maximums supportés par chaque produit du compartiment. Veuillez à ne pas dépasser ces poids, afin de garantir la qualité et la durabilité du produit. Il est également important de se rappeler que les poids indiqués doivent être RÉPARTIS sur toute la surface du rayon.

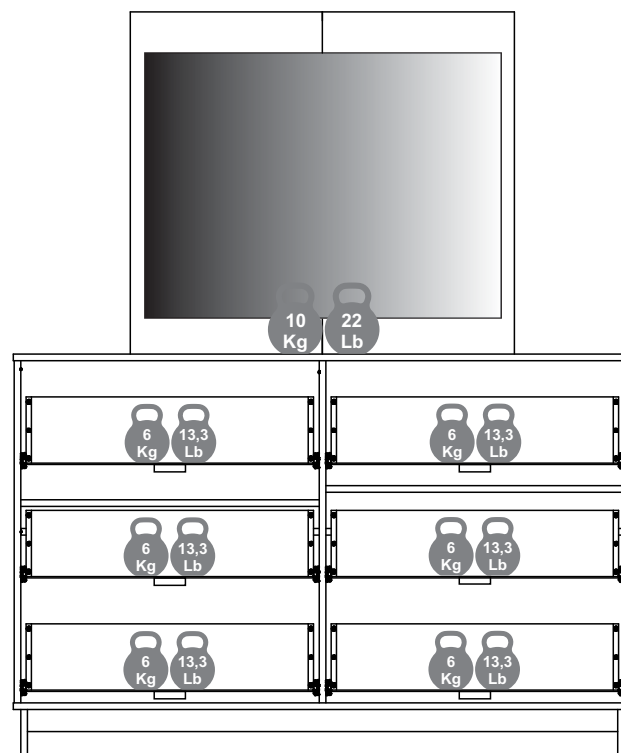



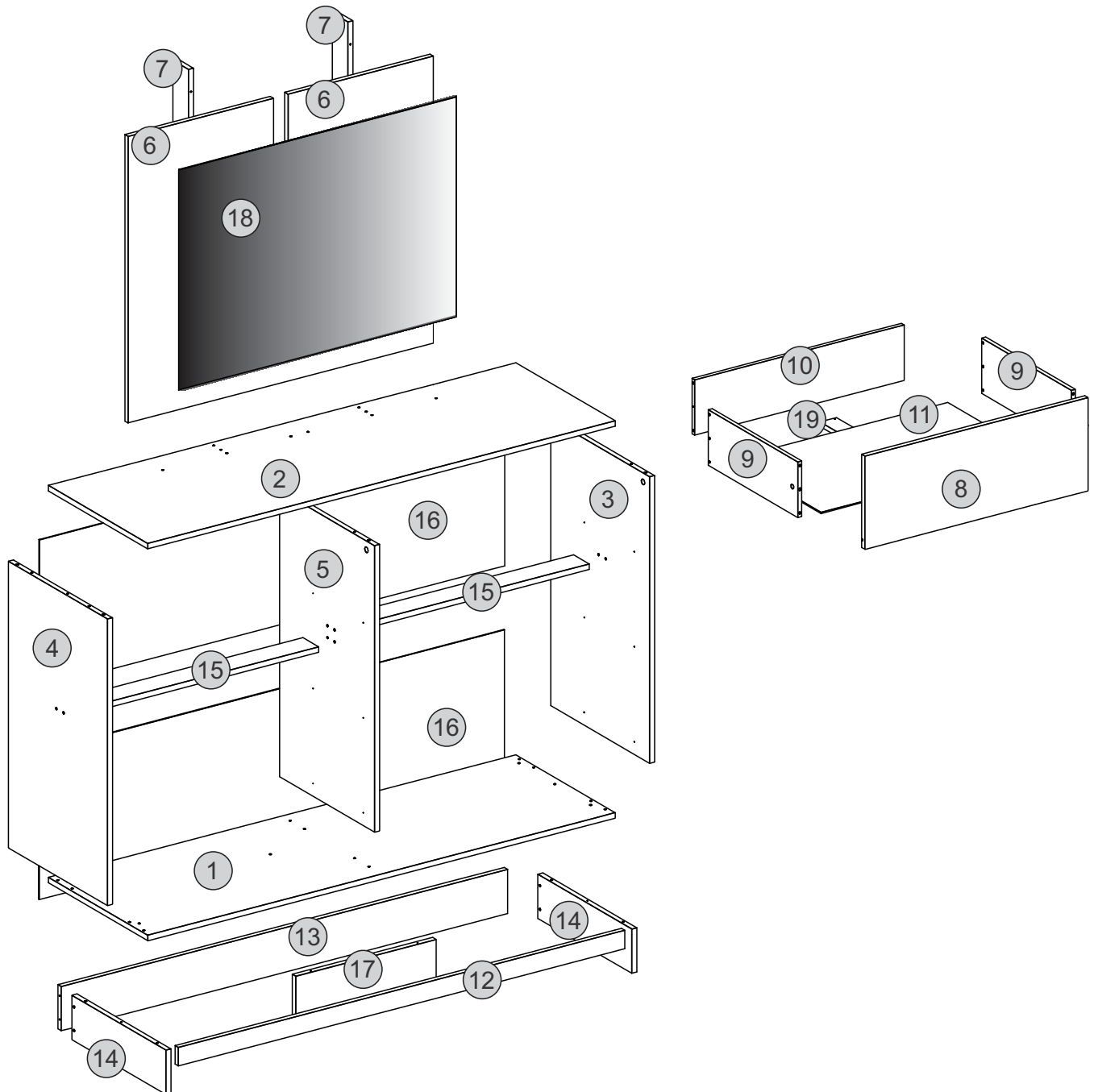







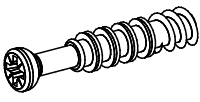



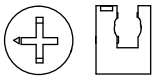
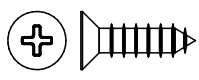
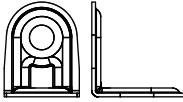
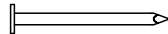

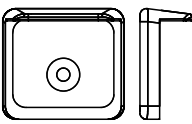
Conocer mejor las piezas de su producto
Getting to know your product parts better
Conhecendo melhor as peças do seu produto
Mieux connaître les pièces de votre produit

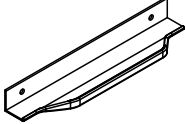

Conocer mejor las piezas de su producto / Getting to know your product parts better
Conhecendo melhor as peças do seu produto / Mieux connaître les pièces de votre produit

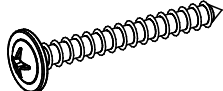
#	Ct. Qt.	Español	English	Português	Français	mm in
1	1	Base	Base	Base	Fond	1400 x 444 x 15 mm 55,12 x 17,48 x 0,59 in
2	1	Tapa	Top	Tampo	Dessus de Tiroir	1400 x 444 x 15 mm 55,12 x 17,48 x 0,59 in
3	1	Lateral Derecha	Right Side	Lateral Direita	Cotè Droit	775 x 442 x 15 mm 30,52 x 17,40 x 0,59 in
4	1	Lateral Izquierda	Left Side	Lateral Esquerda	Cotè Gauche	775 x 442 x 15 mm 30,52 x 17,40 x 0,59 in
5	1	División	Division	Divisão	Séparateur	775 x 424 x 15 mm 30,52 x 16,70 x 0,59 in
6	2	Panel de Espejo	Mirror Panel	Painel do Espelho	Panneau Miroir	775 x 435 x 15 mm 30,52 x 17,13 x 0,59 in
7	2	Refuerzo de Panel	Panel Reinforcement	Reforço do Painel	Renfort de Panneau	700 x 70 x 15 mm 27,56 x 2,75 x 0,59 in
8	6	Frente Cajón	Drawer Front	Frente de Gaveta	Façade Tiroir	668 x 252 x 15 mm 26,30 x 9,93 x 0,59 in
9	12	Lateral Cajón	Drawer Side	Lateral de Gaveta	Cotè Droit et Gauche Tiroir	400 x 150 x 15 mm 15,75 x 5,91 x 0,59 in
10	6	Trasero Cajón	Drawer Back	Costa de Gaveta	Pièce Arrière Tiroir	621 x 150 x 15 mm 24,45 x 5,91 x 0,59 in
11	6	Fondo Cajón	Drawer Bottom	Fundo de Gaveta	Fond Tiroir	651 x 405 x 3 mm 25,63 x 15,95 x 0,12 in
12	1	Zócalo Delantero	Front Baseboard	Rodapé Dianteiro	Socle Avanti	1337 x 50 x 15 mm 52,64 x 1,97 x 0,59 in
13	1	Zócalo de atrás	Back Baseboard	Rodapé Traseiro	Socle Arrière	1337 x 120 x 15 mm 52,64 x 4,73 x 0,59 in
14	2	Zócalo Lateral	Side Baseboard	Rodapé Lateral	Socle Cotè	420 x 120 x 15 mm 16,54 x 4,73 x 0,59 in
15	2	Travesaño	Rail	Travessa	Voie	676 x 70 x 15 mm 26,62 x 2,75 x 0,59 in
16	2	Costado	Back Panel	Costa	Pièce Arrière	1393 x 400 x 3 mm 54,85 x 15,75 x 0,12 in
17	1	Zócalo Interior	Internal Baseboard	Rodapé Interno	Socle Interne	420 x 120 x 15 mm 16,54 x 4,73 x 0,59 in
18	1	Espejo	Mirror	Espelho	Miroir	830 x 700 x 3 mm 32,67 x 27,56 x 0,12 in
19	6	Refuerzo de Cajón	Drawer Reinforcement	Reforço da Gaveta	Renfort de Tiroir	400 x 50 x 15 mm 15,75 x 1,97 x 0,59 in

Y estos son sus Accesorios
And these are your Accessories
E estes são os seus Acessórios
ET voici vos Accessoires

A  (18x)	B  Ø4,0x50mm/0,16x1,97in (52x)	C  (1x)	D  Ø6x30mm/0,24x1,18in (76x)
E  (6x)	F  Ø4,0x14mm/0,16x0,56in (78x)	G  (8x)	H  (44x)
I  (1x)	J  (8x)	K  (72x)	L  (6x)
M  (6x)	O  (26x)	P  (2x)	Q  (4x)
R  Ø3,5x30mm/0,13x1,18in (2x)	S  (2x)	T  Ø3,5x40mm/0,14x1,58in (12x)	U  (12x)

HERRAMIENTAS NECESARIAS / TOOLS REQUIRED / FERRAMENTAS NECESSÁRIAS / OUTILS NÉCESSAIRES

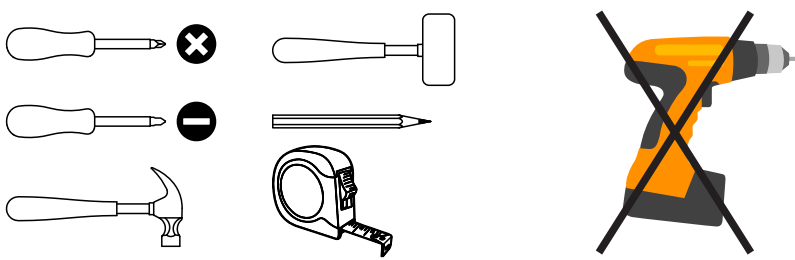

ES: NO UTILICE UN DESTORNILLADOR ELÉCTRICO O A BATERÍADO
 EN: NOT USE A BATTERY OR ELECTRIC SCREWDRIVER
 PT: NÃO UTILIZE PARAFUSADEIRA ELÉTRICA OU À BATERIA
 FR: NE PAS UTILISER DE TOURNEVIS ÉLECTRIQUE OU À BATTERIE

Y si lo necesitas, mide en la regla al lado
 And if you need to, measure on the ruler beside
 E se precisar, meça na régua ao lado
 ET si vous en avez besoin, mesurez sur la règle à côté

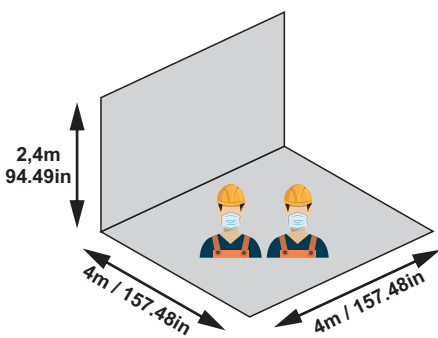
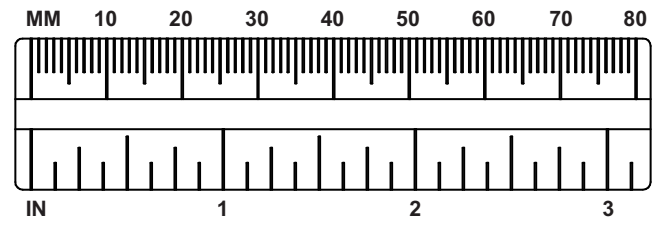

NÚMERO DE PERSONAS Y ÁREA DE ARMADO
NUMBER OF PEOPLE AND ASSEMBLY AREA
NÚMERO DE PESSOAS E ÁREA DE MONTAGEM
NOMBRE DE PERSONNES ET ZONE DE RASSEMBLEMENT

1

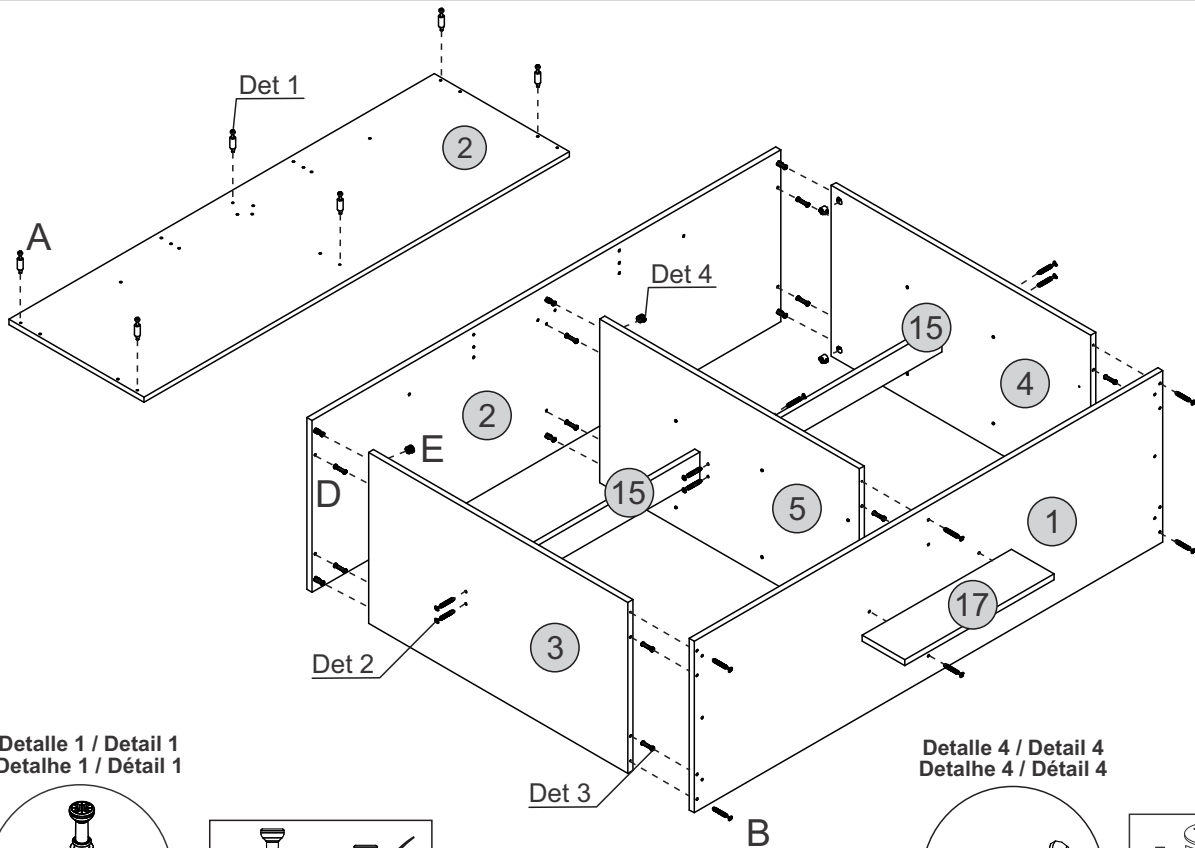

Detalle 2 / Detail 2
 Detalhe 2 / Détail 2

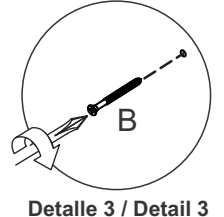

Detalle 3 / Detail 3
 Detalhe 3 / Détail 3



Detalle 1 / Detail 1
 Detalhe 1 / Détail 1

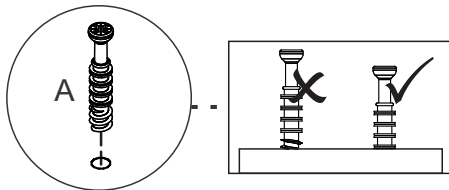

Detalle 4 / Detail 4
 Detalhe 4 / Détail 4

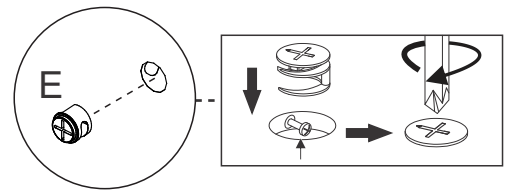

2

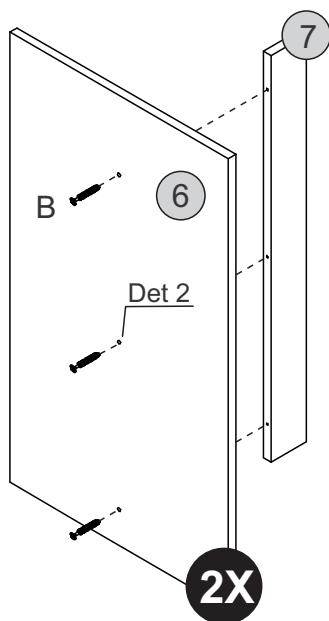

Detalle 5 / Detail 5
 Detalhe 5 / Détail 5

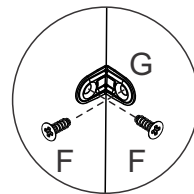

Detalle 2 / Detail 2
 Detalhe 2 / Détail 2

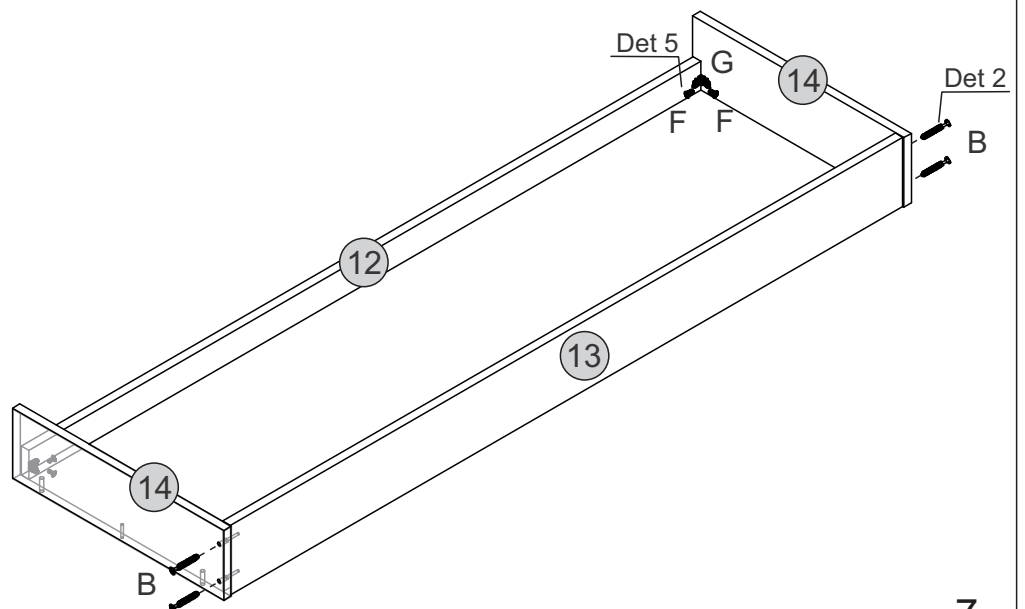
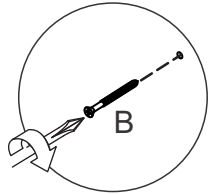

3

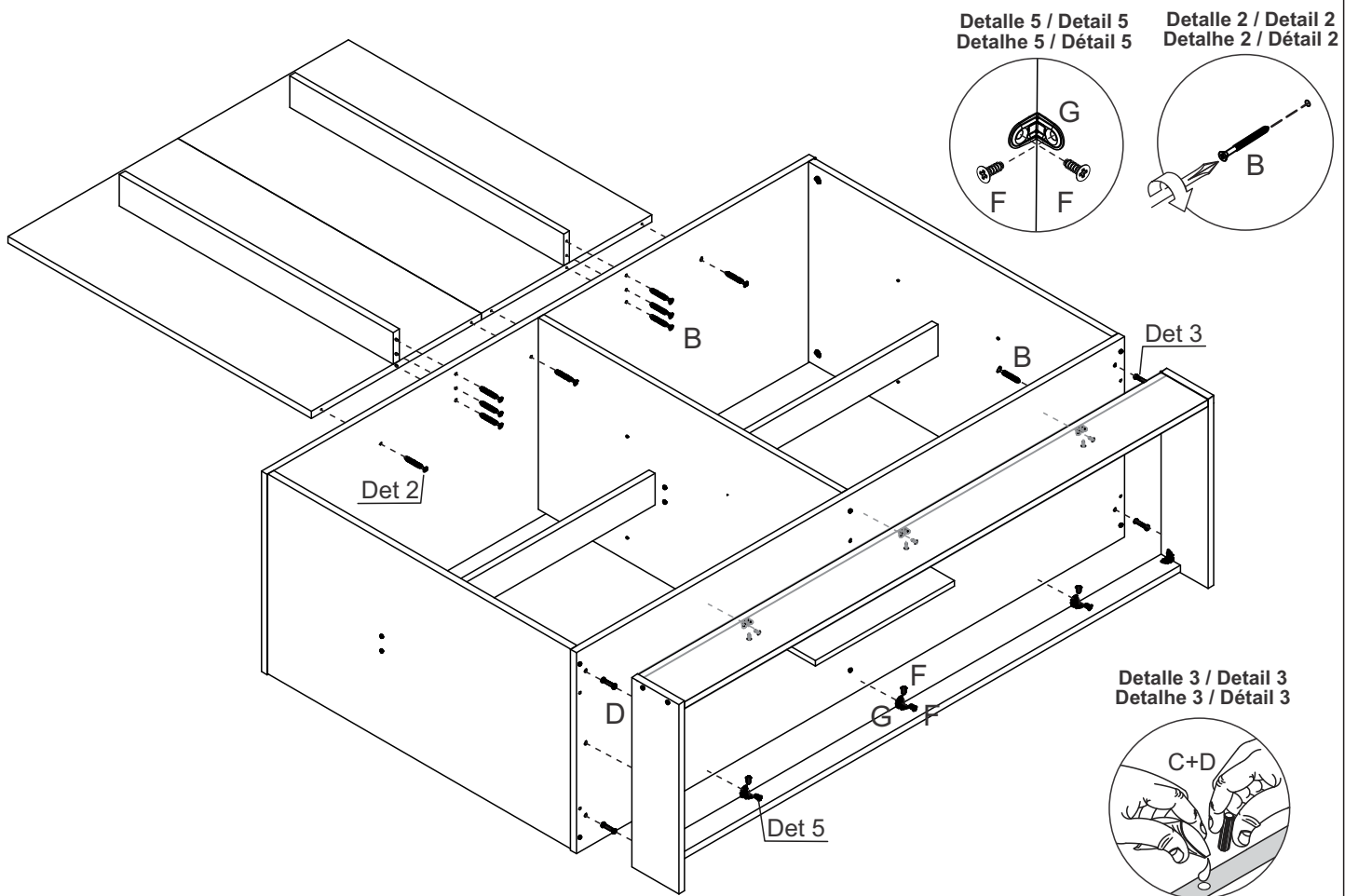

4

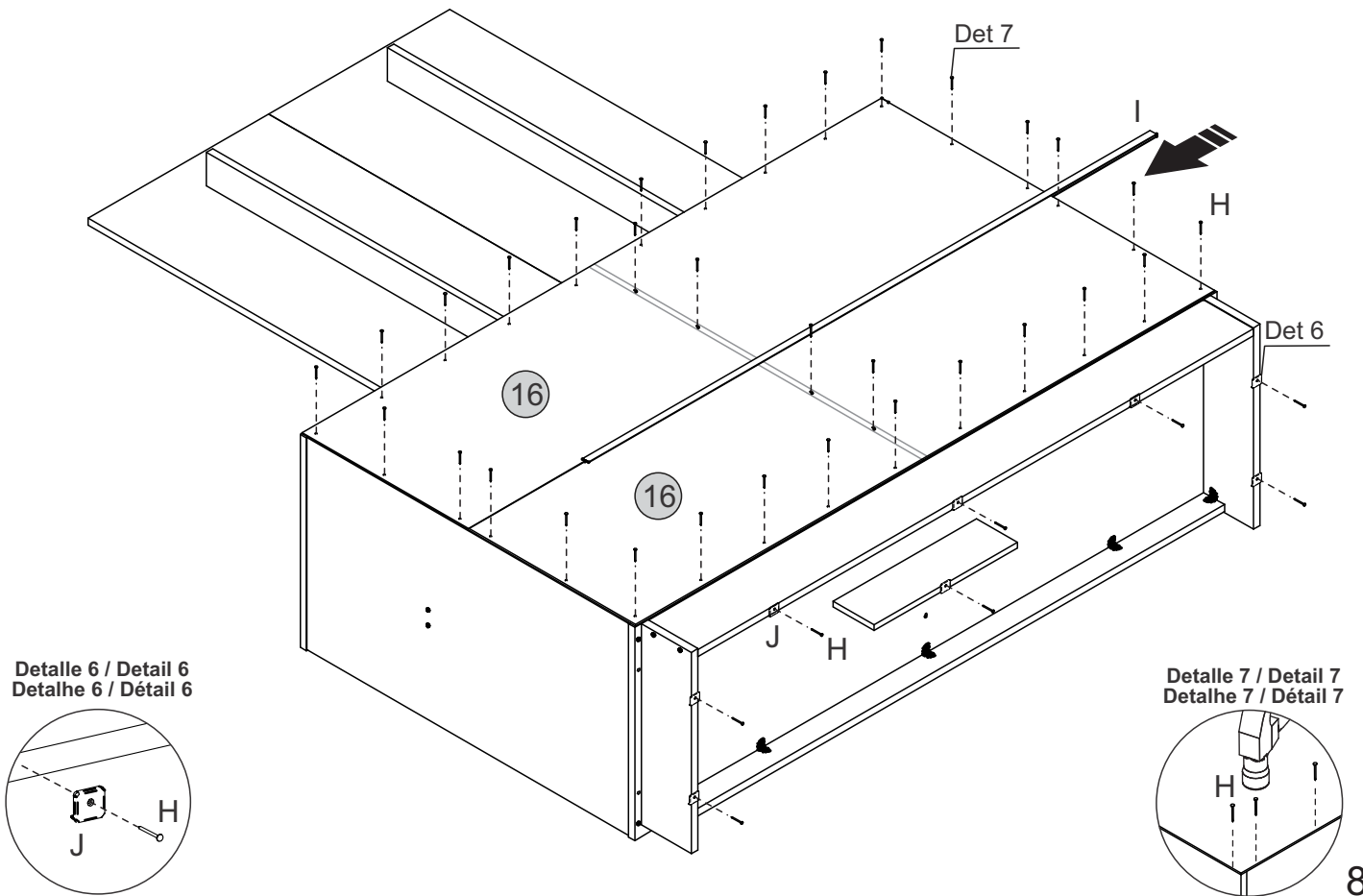

5

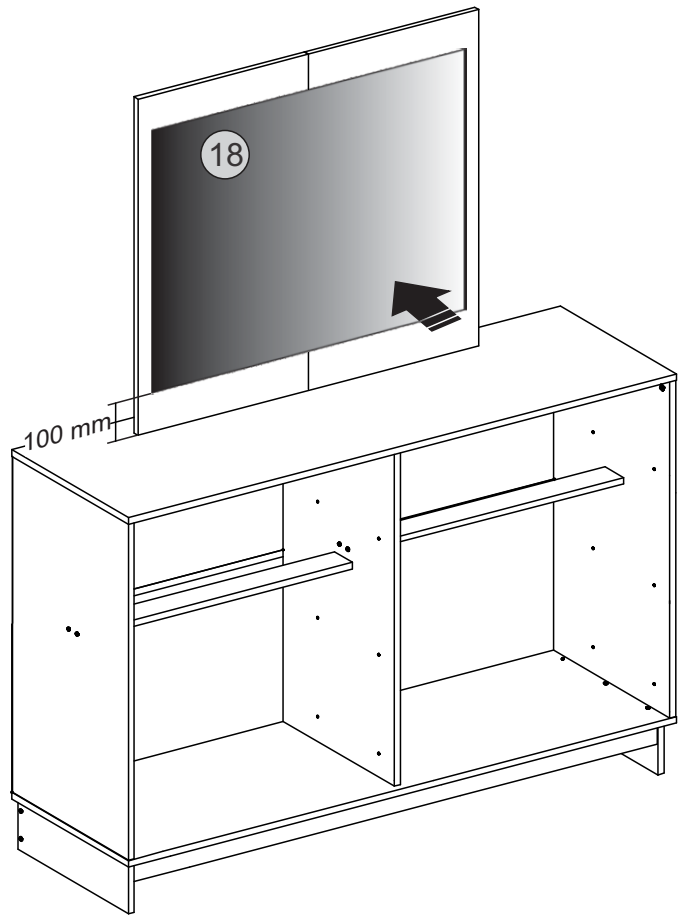
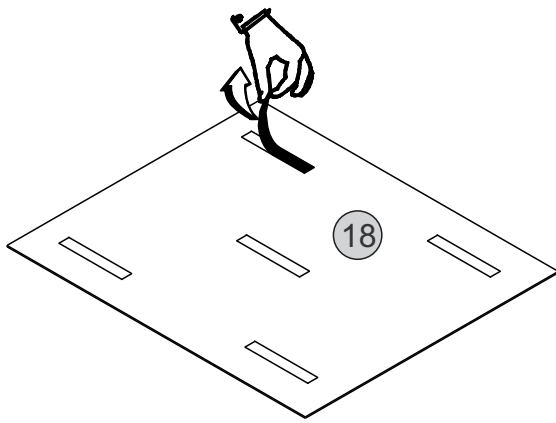

6

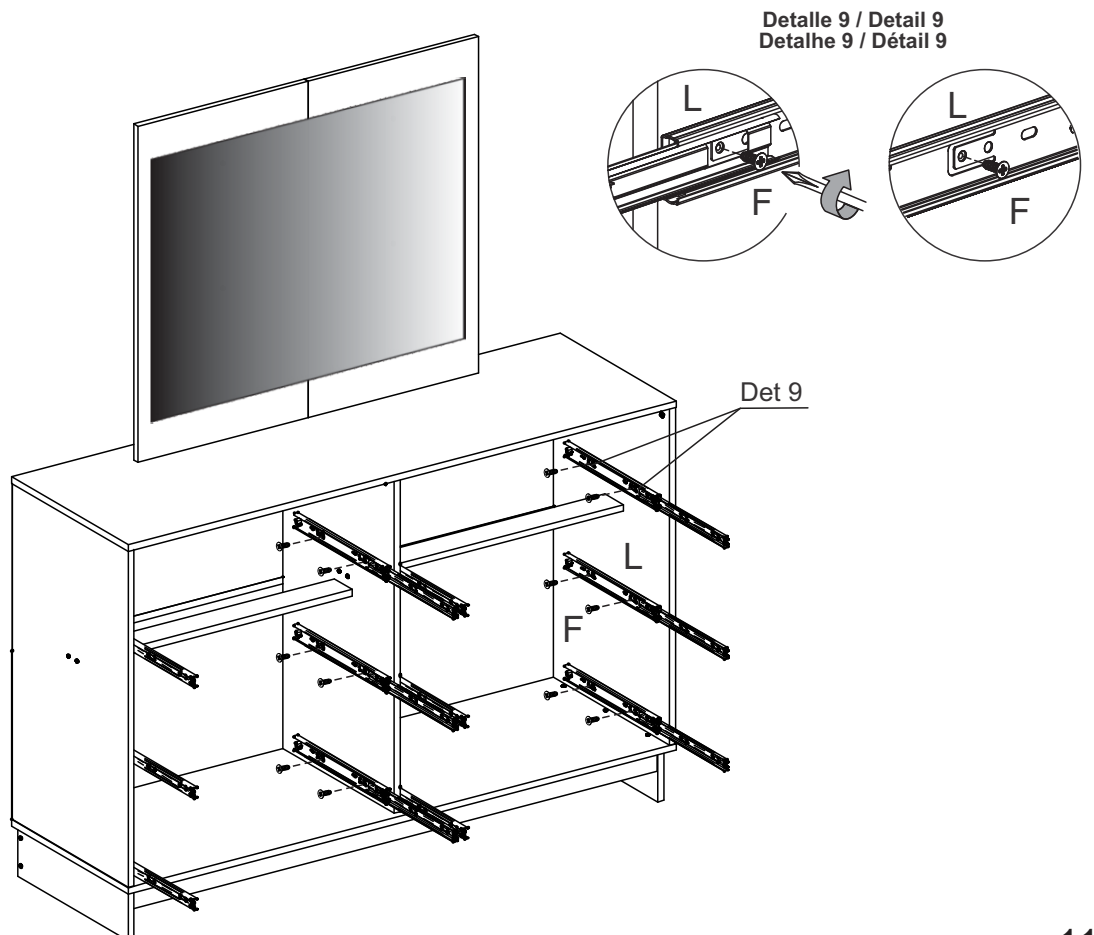

7

Detalle 3 / Detail 3
 Detalhe 3 / Détail 3

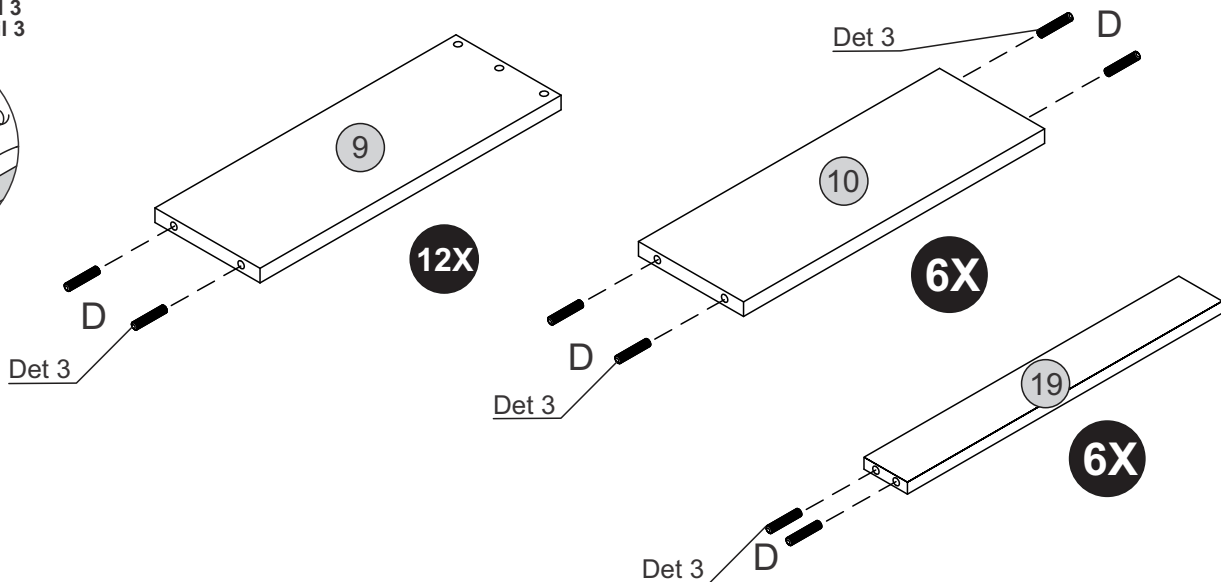

8

Detalle 4 / Detail 4
 Detalhe 4 / Détail 4

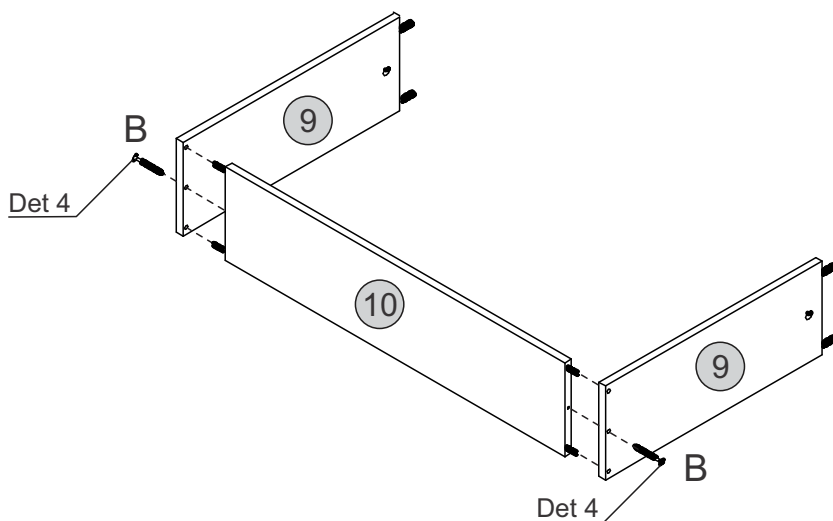
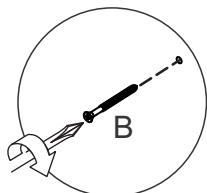

6X

9

Detalle 10 / Detail 10
 Detalhe 10 / Détail 10

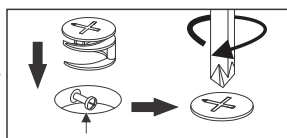
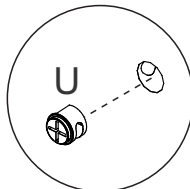

Detalle 3 / Detail 3
 Detalhe 3 / Détail 3

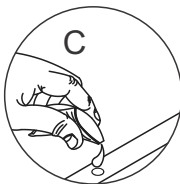

Detalle 1 / Detail 1
 Detalhe 1 / Détail 1

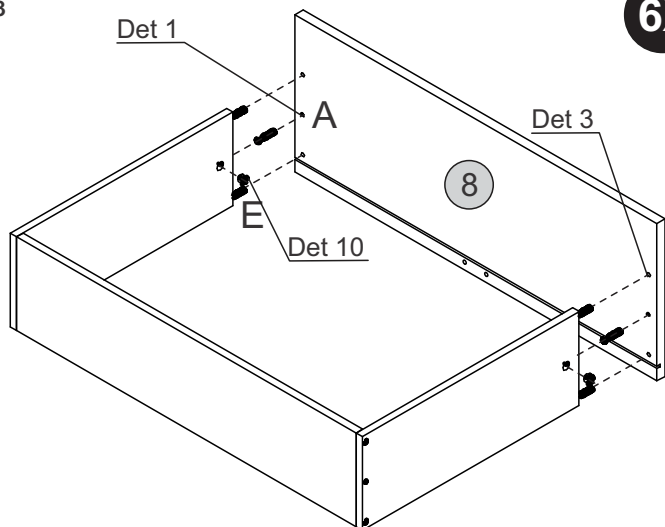
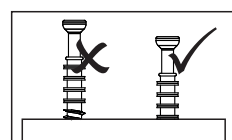
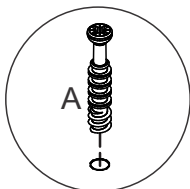

6X

10

Detalle 7 / Detail 7
Detalhe 7 / Détail 7

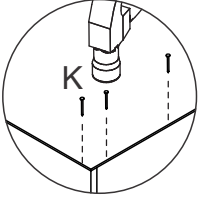

Detalle 3 / Detail 3
Detalhe 3 / Détail 3

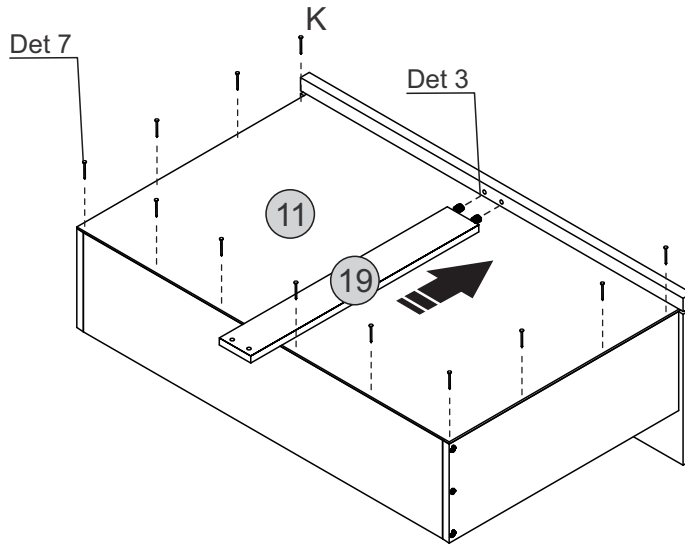
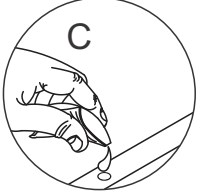

6X

11

Detalle 11 / Detail 11
Detalhe 11 / Détail 11

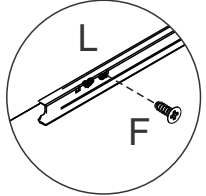

Detalle 11 / Detail 11
Detalhe 11 / Détail 11

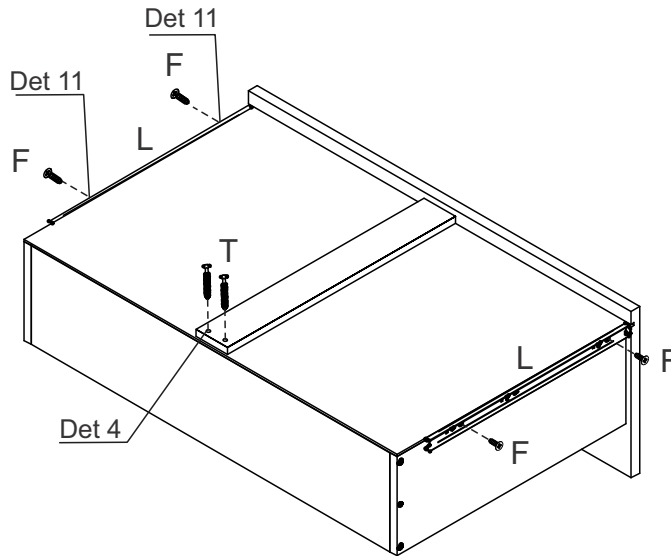
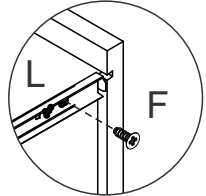

6X

Detalle 4 / Detail 4
Detalhe 4 / Détail 4

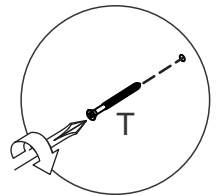

12

Detalle 12 / Detail 12
Detalhe 12 / Détail 12

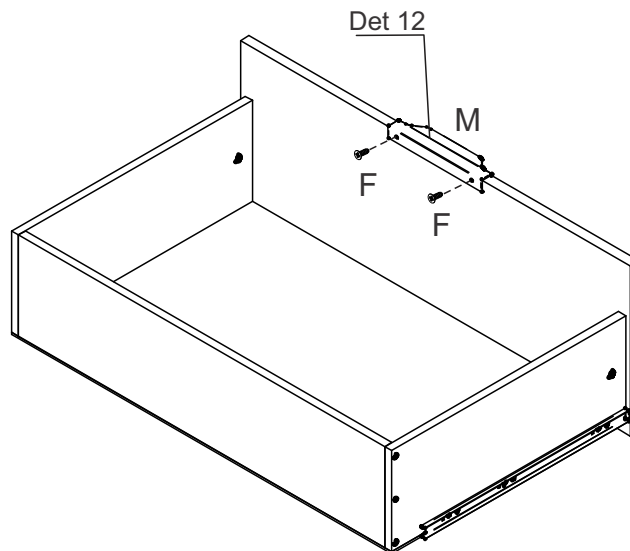
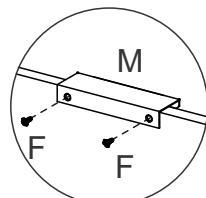

6X

13

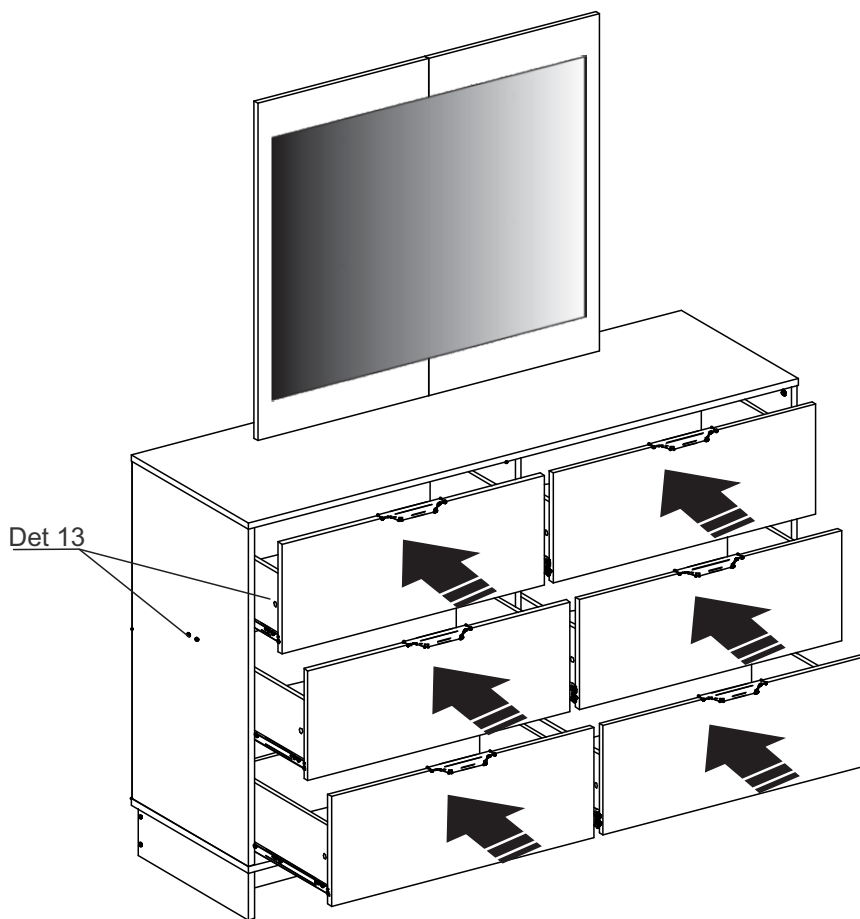

Detalle 13 / Detail 13
Detalhe 13 / Détail 13

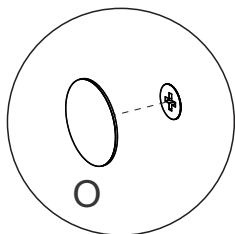

14

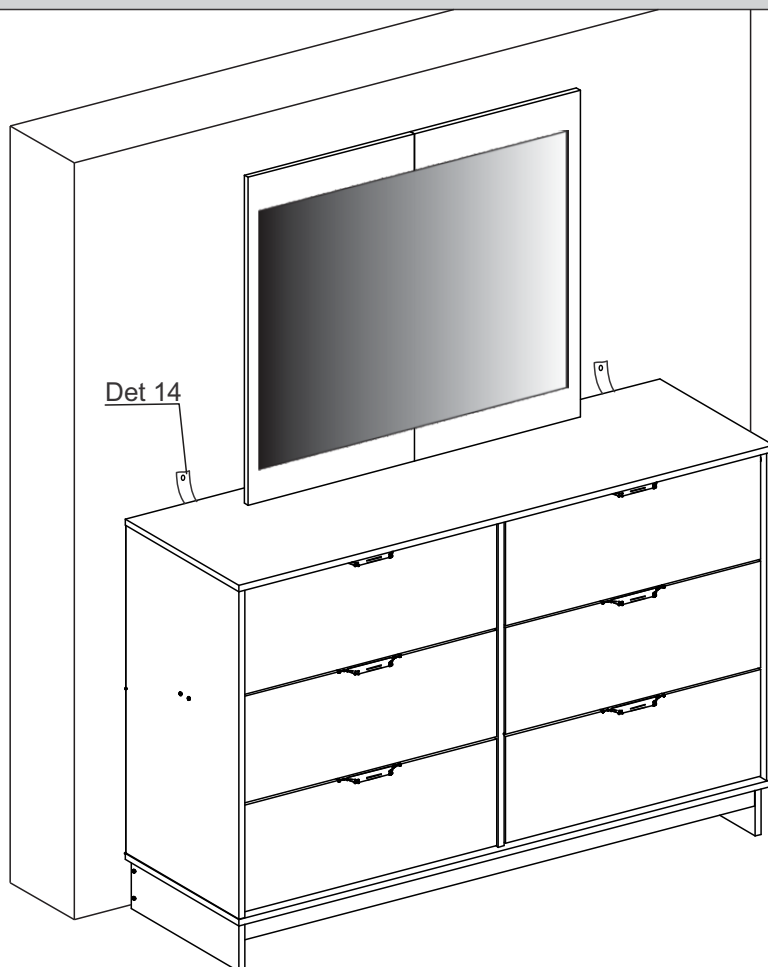

Detalle 14 / Detail 14
Detalhe 14 / Détail 14

