

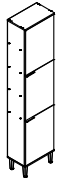

CARRARO
MÓVEIS

Rua Nelson Carraro, 2001 - Bento
Gonçalves - Rio Grande do Sul - Brasil -
Cep: 95702-798 Fone: (55) 54 3455 12 12
www.carraro.com.br



Ref. 2510

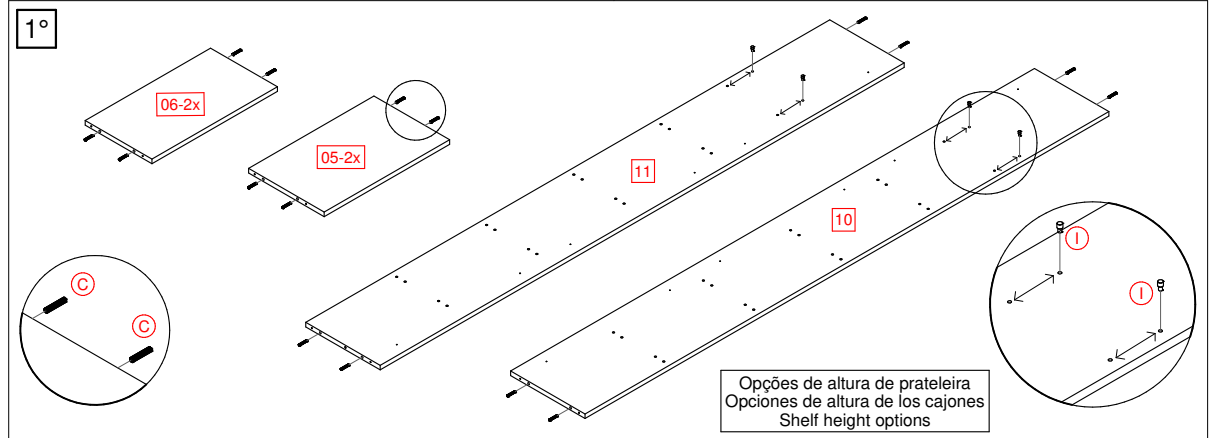
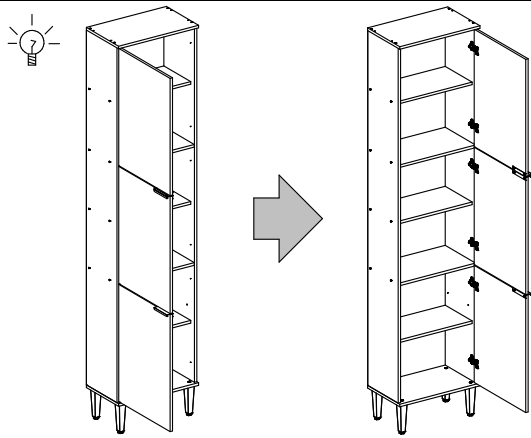

Opções de altura de prateleira
Opciones de altura de los cajones
Shelf height options

ATENÇÃO!

1-Ler e observar atentamente toda a instrução antes de iniciar a montagem.
2-A montagem do produto deverá ser feita em uma superfície limpa e plana. Aconselhamos utilizar a embalagem para forrar o chão a fim de não danificar o produto.

ATENCIÓN

1-Leer y observar con mucha atención toda la instrucción antes de empezar el montaje.
2 - El montaje del producto deberá ser hecho en una superficie limpia y plana. Aconsejamos poner el embalaje del producto en el suelo de manera a evitar daños en el mismo.

ATTENTION!

1-Please, read and check carefully the whole instruction before assembling.
2-The assembly should be carried out on a clean and flat surface. We suggest you use the packaging to cover the floor in order to do not damage it and the product.

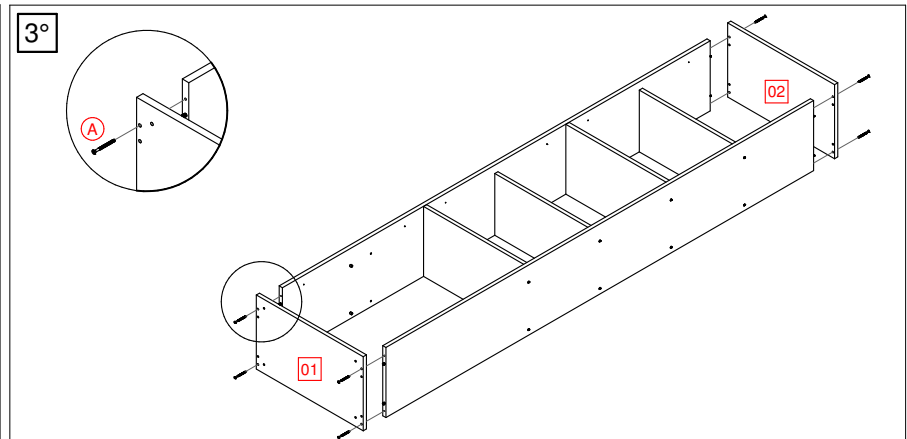
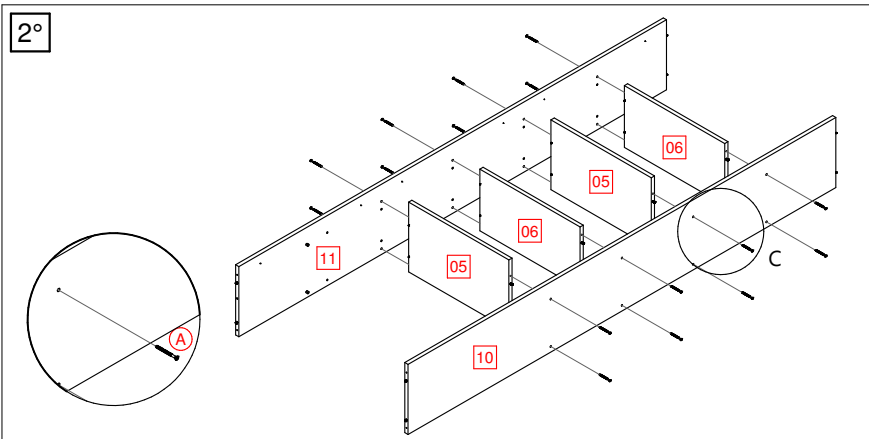

LIMPEZA!

1-Utilize pano levemente umedecido com água seguido de pano seco.
2-Não utilizar produtos químicos ou abrasivos.

LIMPIEZA

1-Utilizar um paño húmedo con agua y después pasar una paño seco.
2-No utilizar productos químicos o abrasivos.

CLEANING

1-Use a slightly wet cloth followed by a dry one.
2-Do not use chemical or abrasive products.

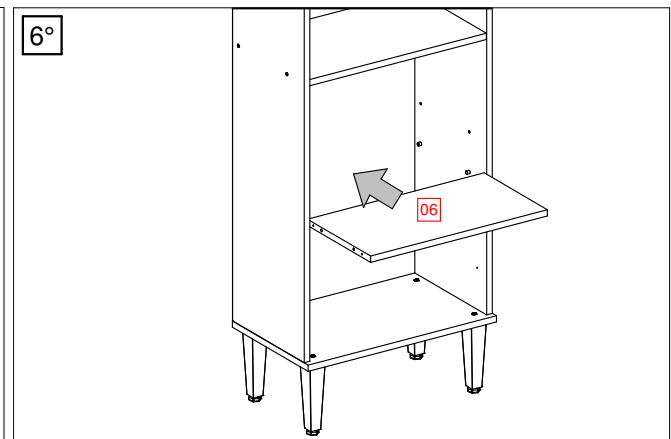
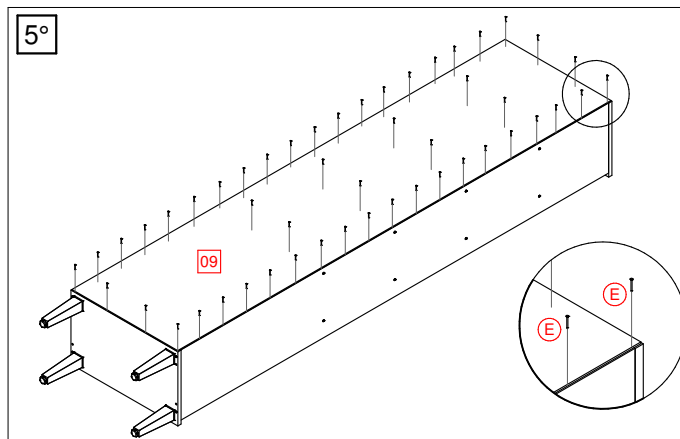
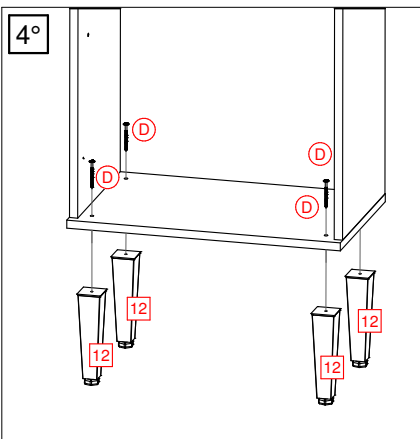

Herramientas Necesarias (no suministradas)
Tools Required (not supplied)
Ferramentas Necessárias (não fornecidas)

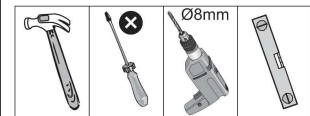

Pessoas necessárias para a montagem
Personas necesarias para el montaje
People required for assembly

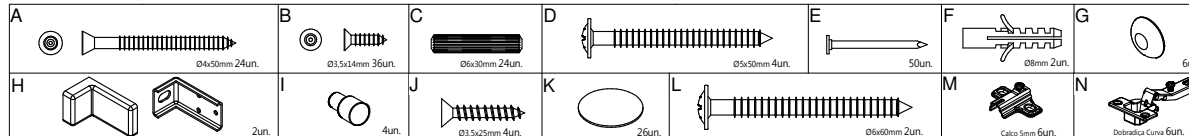

Nº	Qtde	Español	English	Português	Nº	Qtde	Español	English	Português
01	1	Base	Base	Base	09	1	Costado	Back Panel	Costa
02	1	Tapa	Top	Tampo	10	1	Lateral Derecha	Right Side	Lateral Dereita
05	2	Repisa Mayor	Large Shelf	Prateleira Maior	11	1	Lateral Izquierda	Left Side	Lateral Esquerda
06	3	Repisa Menor	Small Shelf	Prateleira Menor	12	4	Pie Plástico	Plastic Foot	Pé Plástico
07	3	Puerta	Door	Porta	13	3	Manija	Handle	Puxador

7°

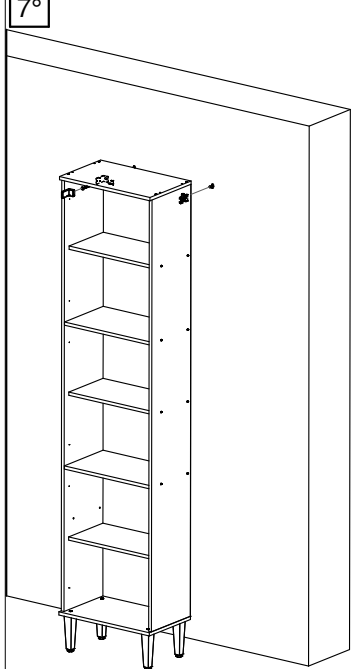

Taladro Ø8
Drill Ø8
Broca Ø8

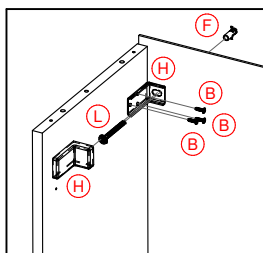
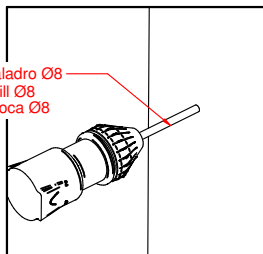

8°

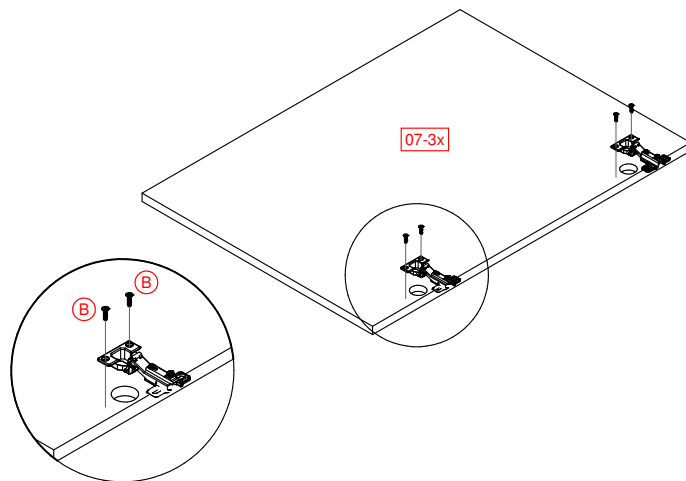
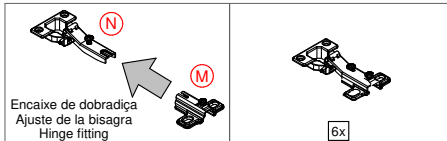

9°

Inserir tapa furos
Inserte la tapa del orificio
Insert hole cover

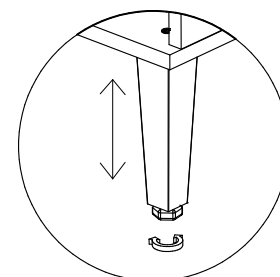
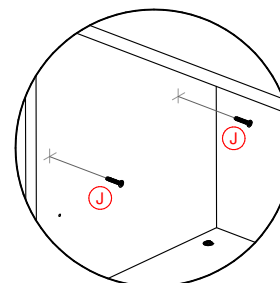
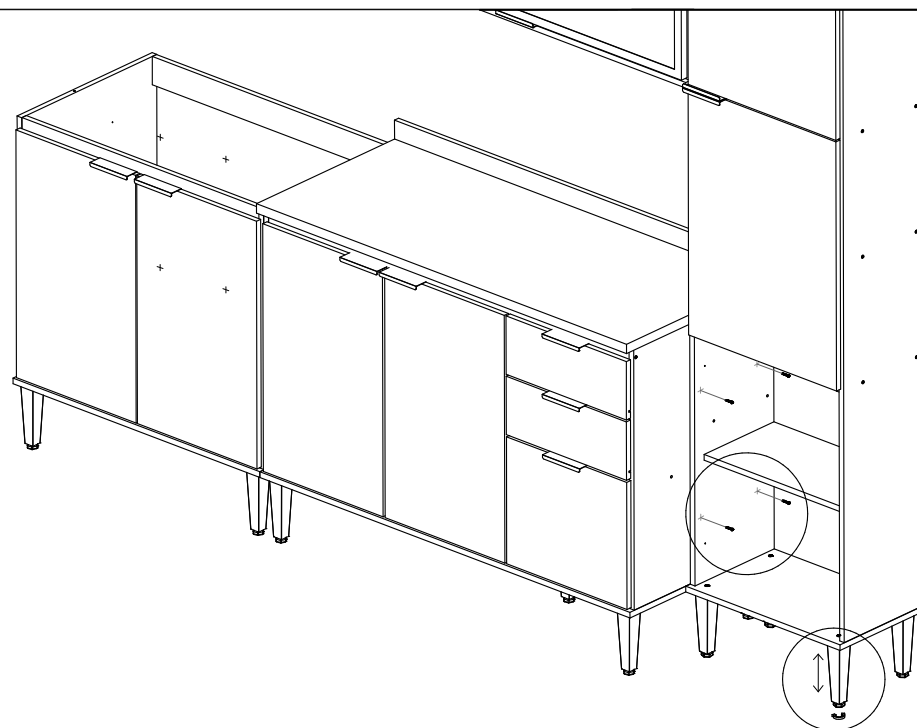
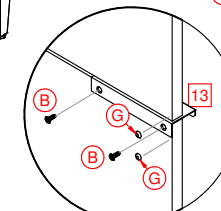
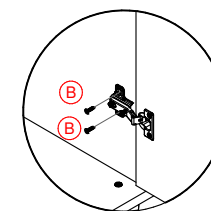
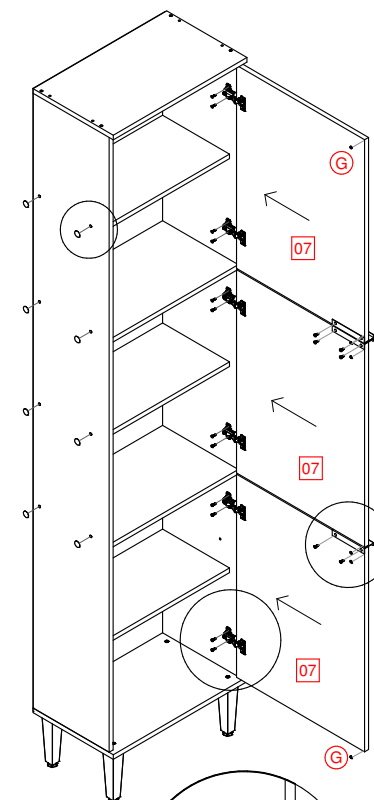
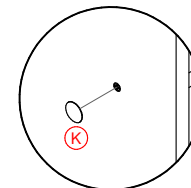

Ajuste de las Puertas / Door Adjustment / Ajuste das Portas

Ajuste de la Profundidad
Depth Adjustment
Ajuste de Profundidade

Ajuste del Alto
Height Adjustment
Ajuste de Altura

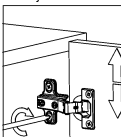
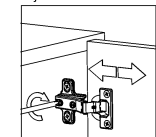

Ajuste Interno / Internal Adjustment
Ajuste Interno

Encaje de la Puerta/Door
Setting/Encaixe da Porta

