

Ref. 2502

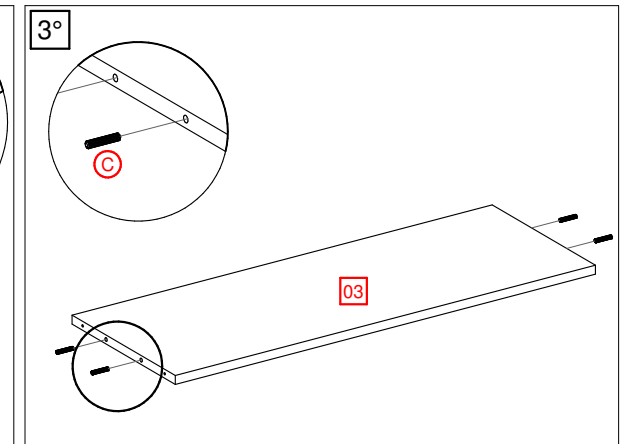
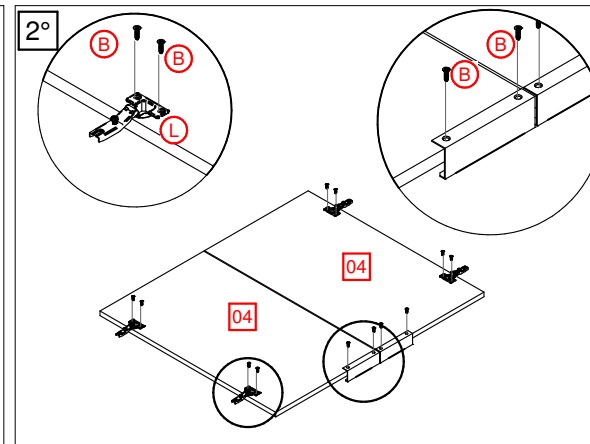
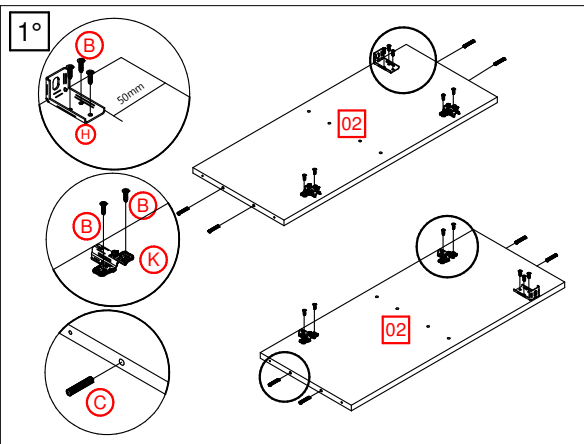

ATENÇÃO!

1-Ler e observar atentamente toda a instrução antes de iniciar a montagem.
2-A montagem do produto deverá ser feita em uma superfície limpa e plana. Aconselhamos utilizar a embalagem para forrar o chão a fim de não danificar o produto.

ATENCIÓN

1-Leer y observar con mucha atención toda la instrucción antes de empezar el montaje.
2 - El montaje del producto deberá ser hecho en una superficie limpia y plana. Aconsejamos poner el embalaje del producto en el suelo de manera a evitar daños en el mismo.

ATTENTION!

1-Please, read and check carefully the whole instruction before assembling.
2-The assembly should be carried out on a clean and flat surface. We suggest you use the packaging to cover the floor in order to do not damage it and the product.

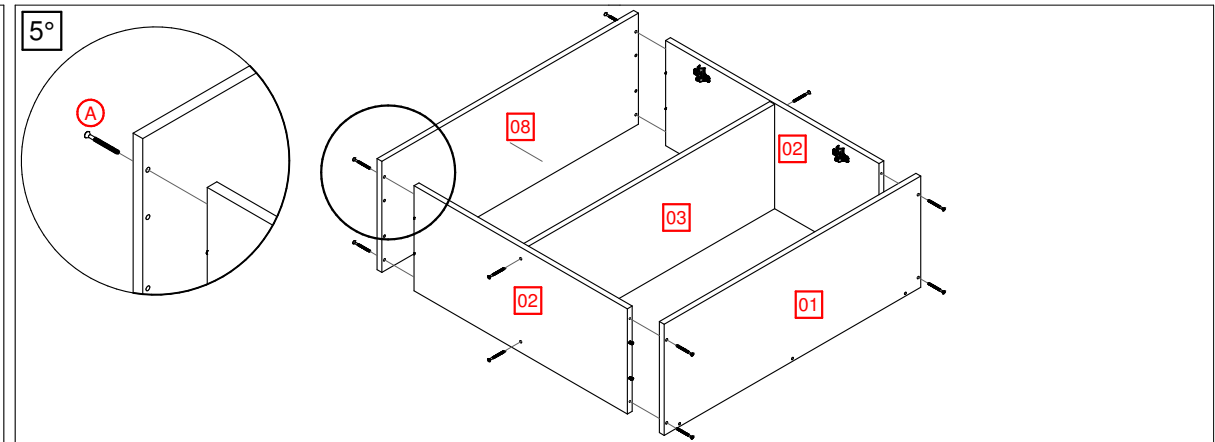
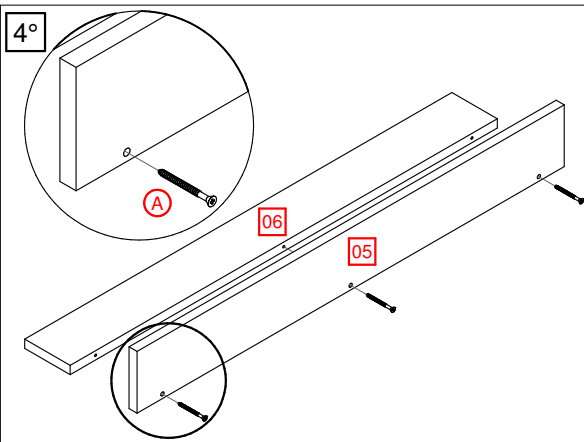

LIMPEZA!

1-Utilize pano levemente umedecido com água seguido de pano seco.
2-Não utilizar produtos químicos ou abrasivos.

LIMPIEZA

1-Utilizar um paño húmedo con agua y después pasar una paño seco.
2-No utilizar productos químicos o abrasivos.

CLEANING

1-Use a slightly wet cloth followed by a dry one.
2-Do not use chemical or abrasive products.

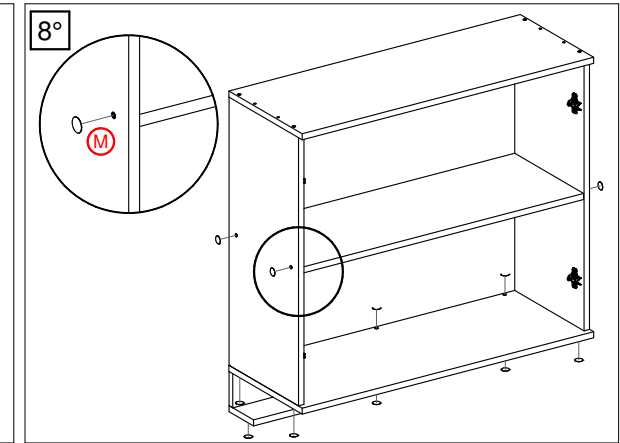
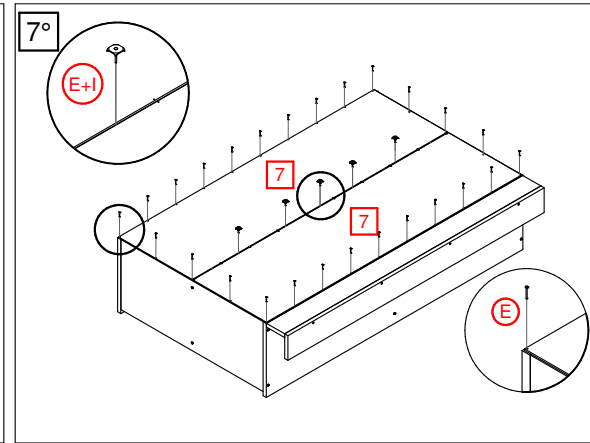
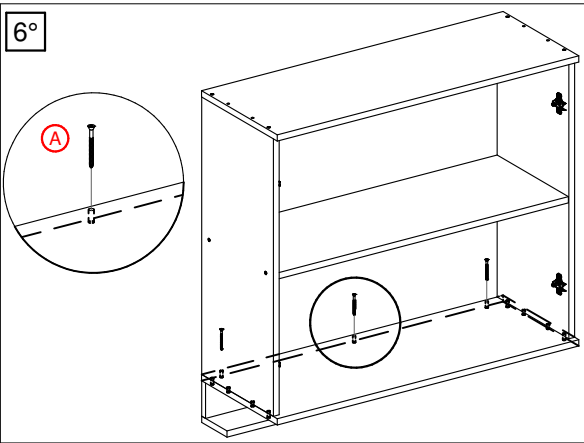

Herramientas Necesarias (no suministradas)
Tools Required (not supplied)
Ferramentas Necessárias (não fornecidas)

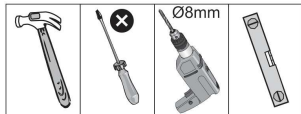

Pessoas necessárias para a montagem
Personas necesarias para el montaje
People required for assembly

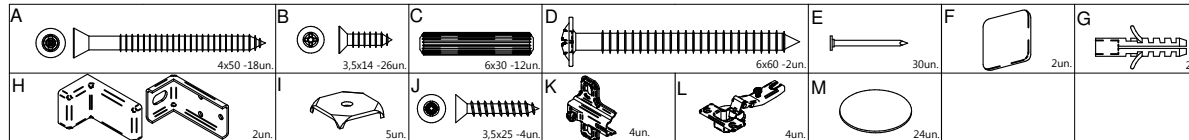

N°	Qtde.	Español	English	Português	N°	Qtde.	Español	English	Português
01	1	Base	Base	Base	06	1	Revés Nicho	Back Niche	Costa Nicho
02	2	Lateral	Side Panel	Lateral	07	2	Revés	Back Panel	Costa
03	1	Rapisa	Shelf	Prateleira	08	1	Tapa	Top Panel	Tampo
04	2	Puerta	Door	Porta	>	2	Tirador	Handle	Puxador
05	1	Rapisa Nicho	Shelf Niche	Prateleira Nicho					

9°

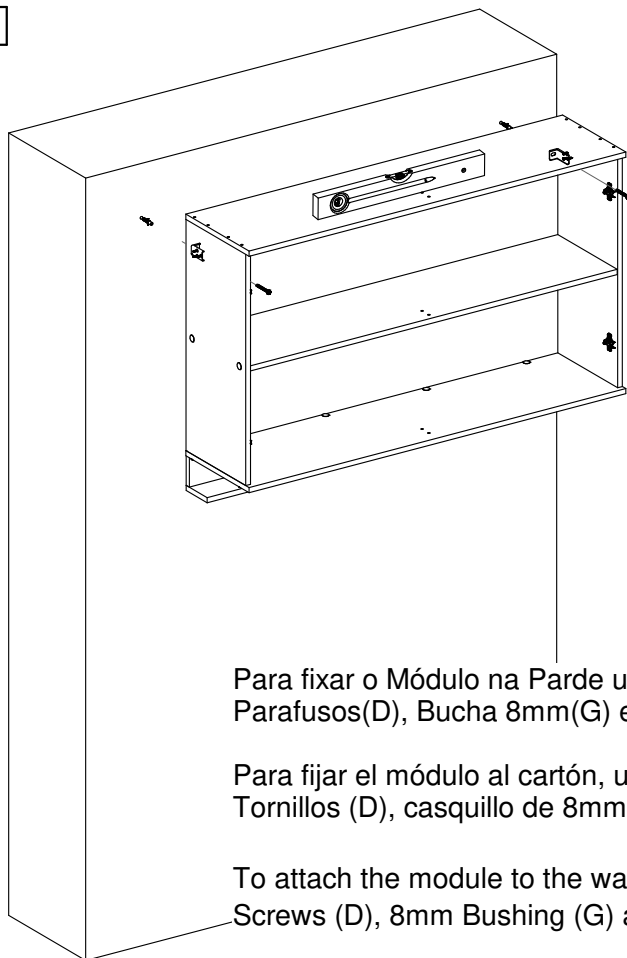

Para fixar o Módulo na Parde utilize o suporte de fixação (H), Parafusos(D), Bucha 8mm(G) e o Acabamento do Suporte.

Para fijar el módulo al cartón, utilice el soporte de fijación (H), Tornillos (D), casquillo de 8mm (G) y el remate del soporte.

To attach the module to the wall, use the mounting bracket (H), Screws (D), 8mm Bushing (G) and the Finishing Support.

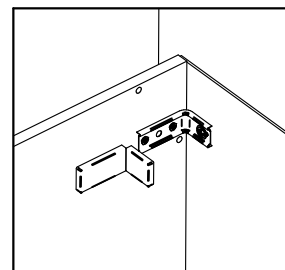
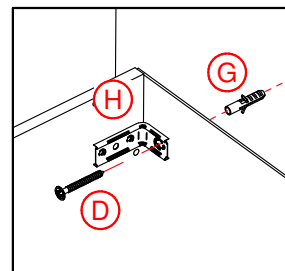
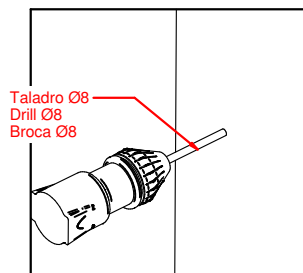

10°

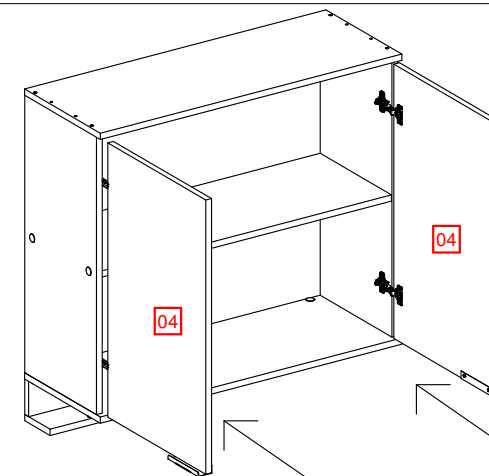

Ajuste de las Puertas / Door Adjustment / Ajuste das Portas

Ajuste de la Profundidad
Depth Adjustment
Ajuste de Profundidade

Ajuste del Alto
Height Adjustment
Ajuste de Altura

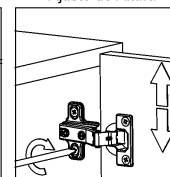
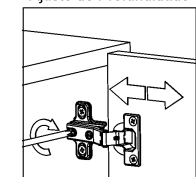

Ajuste Interno / Internal Adjustment
Ajuste Interno

Encaje de la Puerta/Door
Setting/Encaixe da Porta

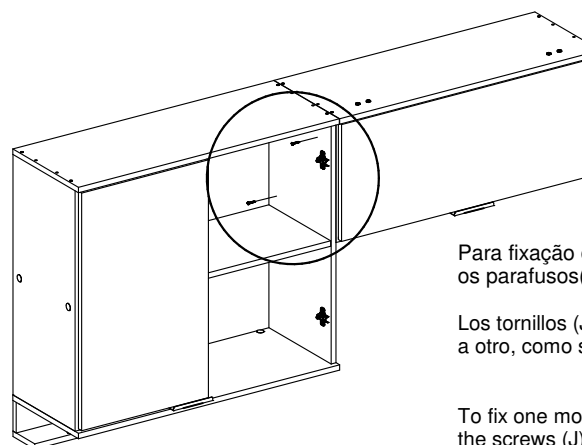
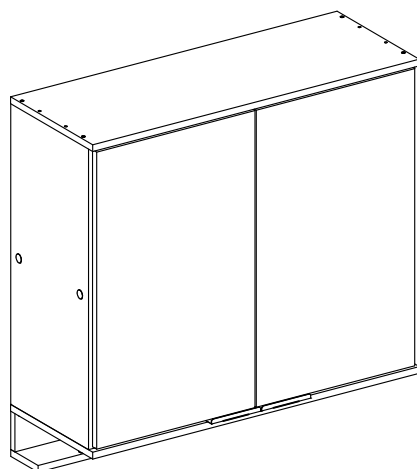
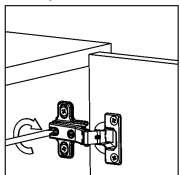
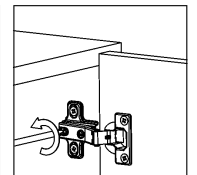
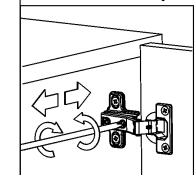

Para fixação de um módulo ao outro é necessário utilizar os parafusos(J), assim como demonstrado no desenho.

Los tornillos (J) deben utilizarse para fijar un módulo a otro, como se muestra en el dibujo.

To fix one module to the other it is necessary to use the screws (J), as shown in the drawing.

