

Este es el producto que ha comprado!
This is the product you have purchased!
Esse é o produto que você adquiriu!
Voici le produit que vous avez acheté!

Ref. 1173

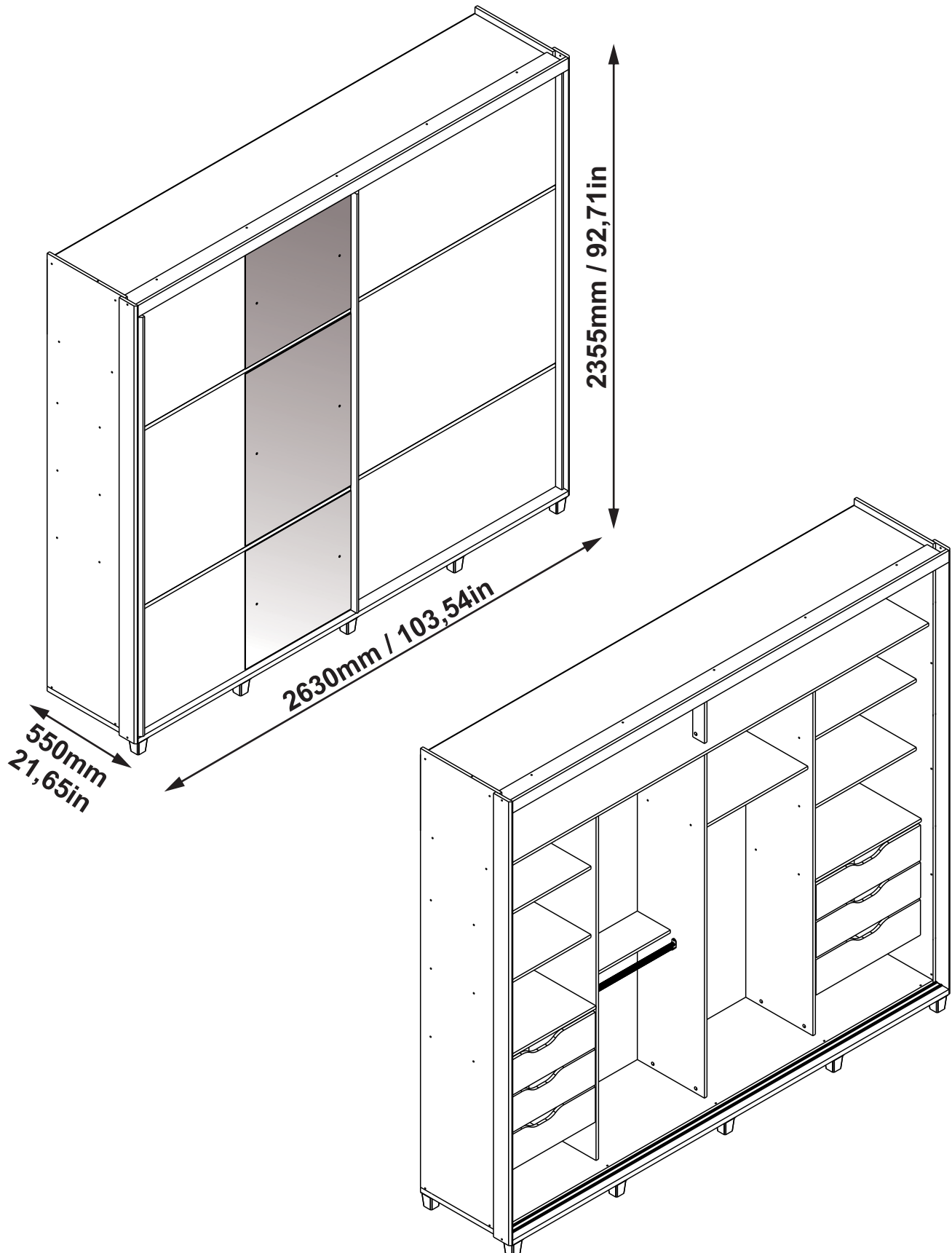

RECOMENDACIONES PARA EL USO Y CUIDADO DEL PRODUCTO
RECOMMENDATIONS FOR THE USE AND CARE OF THE PRODUCT
RECOMENDAÇÕES DE USO E CUIDADOS COM O PRODUTO
RECOMMANDATIONS POUR L'UTILISATION ET L'ENTRETIEN DU PRODUIT



ES: Lea cuidadosamente el manual y siga en el orden indicado las instrucciones de ensamble.
EN: Read the manual carefully and follow the assembly instructions in the order listed.
PT: Leia o manual com atenção e siga as instruções de montagem na ordem listada.
FR: Lisez attentivement le manuel et suivez les instructions de montage dans l'ordre indiqué.



ES: No pinte ni use elementos abrasivos para limpiar el mueble.
EN: Do not paint or use abrasive items to clean the furniture.
PT: Não pinte ou use itens abrasivos para limpar o móvel.
FR: Ne pas peindre ni utiliser d'objets abrasifs pour nettoyer l'armoire.



ES: No exponga el mueble al calor ni a la humedad.
EN: Do not expose the furniture to heat or humidity.
PT: Não exponha a mobília ao calor ou umidade.
FR: N'exposez pas le meuble à la chaleur ou à l'humidité.



ES: - No arraste el mueble, esto puede causar daños en las piezas.
 - Para desplazar el mueble asegúrese de moverlo cuando este vacío sin objetos.
 - Siempre solicite ayuda a otra persona para moverlo.
EN: - Do not drag the furniture, this can cause damage to the pieces.
 - To move the furniture be sure to move it when it is empty without objects.
 - Always ask someone else to help you move it.
PT: - Não arraste o móvel, pois isso pode causar danos às peças.
 - Para mover o móvel certifique-se de movê-lo quando estiver vazio e sem objetos.
 - Sempre peça a outra pessoa para ajudá-lo a movê-lo.
FR: - Ne traînez pas le meuble, cela peut endommager les pièces.
 - Pour déplacer le meuble veillez à le déplacer lorsqu'il est vide sans objets.
 - Demandez toujours à quelqu'un d'autre de vous aider à le déplacer.

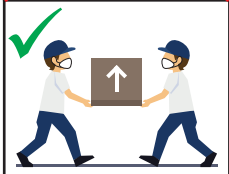

ES: - Limpia regularmente la madera con un paño de microfibra para que no se acumule el polvo y así evitar que el mueble pierda su brillo.
EN: Regularly clean the wood with a microfiber cloth so that dust does not accumulate and thus prevent the furniture from losing its shine.
PT: Limpe regularmente a madeira com um pano de microfibra para que o pó não se acumule e evite que o móvel perca o brilho.
FR: Nettoyez régulièrement le bois avec un chiffon microfibre afin que la poussière ne s'accumule pas et ainsi éviter que le meuble ne perde de son éclat.



ES: No utilice papel periódico para brillar vidrios y/o espejos, esto los puede rayar. Es recomendable utilizar paños que no dejen pelusa.
EN: Do not use newspaper to shine glass and / or mirrors, this can scratch them. It is recommended to use lint-free cloths.
PT: Não use jornal para lustrear vidros e / ou espelhos, pois podem riscá-los. É aconselhável usar panos sem fiapos.
FR: N'utilisez pas de papier journal pour faire briller le verre et/ou les miroirs, cela peut les rayar. Il est conseillé d'utiliser des chiffons non pelucheux.



ES: Evita que el agua entre en contacto con las partes de metal, ya que puede provocar manchas y óxido.
EN: Avoid getting water on metal parts as it can cause stains and rust.
PT: Evite molhar as peças de metal, pois pode causar manchas e ferrugem.
FR: Évitez de mettre de l'eau sur les pièces métalliques car cela peut causer des taches et de la rouille.



ES: Ubica tus productos en una superficie lisa y plana. Utilice una protección entre el mueble y el piso.
EN: Place your products on a smooth, flat surface. Use a protection between the furniture and the floor.
PT: Coloque seus produtos em uma superfície lisa e plana. Use uma proteção entre a mobília e o chão.
FR: Placez vos produits sur une surface lisse et plane. Utilisez une protection entre le meuble et le sol.



ES: Ubica tus productos en una superficie lisa y plana. Utilice una protección entre el mueble y el piso.
EN: Place your products on a smooth, flat surface. Use a protection between the furniture and the floor.
PT: Coloque seus produtos em uma superfície lisa e plana. Use uma proteção entre a mobília e o chão.
FR: Placez vos produits sur une surface lisse et plane. Utilisez une protection entre le meuble et le sol.

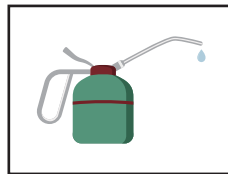

ES: Se recomienda lubricar cada 3 meses rieles, correderas, bisagras y rodachinas.
EN: It is recommended to lubricate the rails, runners, hinges and castors every 3 months.
PT: Recomenda-se a lubrificação de trilhos, corredeiras, dobradiças e rodízios a cada 3 meses.
FR: Il est recommandé de lubrifier les rails, glissières, charnières et roulettes tous les 3 mois.

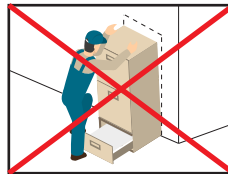

ES: No utilizar las gavetas como escaleras ni permitir que los niños se cuelguen de las puertas.
EN: Do not use drawers as ladders or allow children to hang from doors.
PT: Não use gavetas como escadas, nem permita que crianças se pendurem nas portas.
FR: N'utilisez pas les tiroirs comme échelles et ne laissez pas les enfants se suspendre aux portes.



ES: Evita que el trapeador o elementos similares entren en contacto con tus muebles ya que esto puede deteriorarlos.
EN: Avoid that the mop or similar elements come into contact with your furniture as this can deteriorate them.
PT: Evite que a esfregona ou elementos semelhantes entrem em contacto com os seus móveis, pois pode deteriorá-los.
FR: Évitez que la serpillière ou des éléments similaires entrent en contact avec vos meubles car cela peut les détériorer.



ES: Mantén alejado objetos puntiagudos como tijeras, llaves o cuchillos. Éstos pueden causar cortes y/o rayones.
EN: Keep sharp objects like scissors, keys, or knives away. These can cause cuts and / or scratches.
PT: Mantenha objetos pontiagudos como tesouras, chaves ou facas longe. Isso pode causar cortes e / ou arranhões.
FR: Gardez les objets pointus comme des ciseaux, des clés ou des couteaux à distance. Ceux-ci peuvent provoquer des coupures et/ou des rayures.

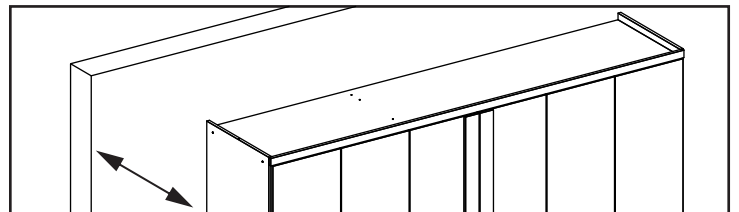

ES: Se recomienda separar de la pared tus productos para que estos puedan tener una circulación de aire natural.
EN: It is recommended to separate your products from the wall so that they can have a natural air circulation.
PT: Recomenda-se separar seus produtos da parede para que tenham uma circulação natural de ar.
FR: Il est recommandé de séparer vos produits du mur afin qu'ils puissent avoir une circulation d'air naturelle.

Consejos de Conservación y Pesos soportados

Conservation Tips and Supported Weights

Dicas de Conservação e Pesos Suportados

Conseils d'entretien et Poids soutenus

ES: 1. No debe utilizarse en la limpieza, abrasivos como lana de acero, alcohol, limón, o productos corrosivos que puedan rayar o quitar la película en los muebles.

2. Cuando la limpieza de muebles en general, napa y formica, deben utilizarse un paño ligeramente humedecido y jabón suave.

3. Para mover el mueble, es importante que este se eleve desde el suelo, debido a que el arrastre puede causar daño estructural.

4. No deje el mueble en exposición a la intemperie.

EN: 1. Do not use abrasive products to clean such as steel wool, alcohol, vinegar, lemon, scouring powder, or corrosive products which can scratch or peel off the protective film of the furniture.

2. The best way to clean your furniture is to use a slightly moistened cloth with a mild soap.

3. To move the furniture assembled, it is important that it is lifted off the ground, because the drag it can cause structural damage.

4. Do not leave your furniture in weather exposure.

PT: 1. Não utilizar na limpeza produtos abrasivos tais como: palha de aço, álcool, vinagre, limão, saponáceo ou produtos corrosivos que possam riscar ou descolar a película protetora dos móveis.

2. Na limpeza de móveis em geral, napas e fórmicas, deve ser utilizado um pano levemente umedecido e sabão neutro.

3. Para a movimentação do móvel, é importante que este seja levantado do chão, pois ao arrastá-lo pode causar avarias estruturais.

4. Não deixe o móvel em exposição a intempéries.

FR: 1. Ne pas utiliser de produits abrasifs dans le nettoyage, tels que: laine d'acier, alcool, vinaigre, citron, poudre à récurer ou autres produits corrosifs pouvant rayer ou faire décoller la pellicule protectrice des meubles.

2. Pour le nettoyage du meuble, il est recommandé d'utiliser un chiffon humide et du savon neutre.

3. Pour déplacer le meuble, il est important de le soulever du sol car le tirer pourrait causer des dommages dans sa structure.

4. Ne pas exposer le meuble aux intempéries.

ES: Por favor, preste atención a los pesos máximos admitidos por cada compartimento del producto. Tenga cuidado de no exceder estos pesos, con el fin de garantizar la calidad y durabilidad del producto. Es importante recordar que los pesos muestran en caso de ser DISTRIBUIDA en toda el área de la plataforma.

EN: Please pay attention to the maximum weights supported by each compartment product. Be careful not to exceed these weights, in order to ensure the quality and durability of the product. It is important to remember also that the weights shown should be DISTRIBUTED throughout the area of the shelf.

PT: Por favor, preste atenção aos pesos máximos suportados por cada compartimento do produto. Cuide para não exceder esses pesos, afim de garantir a qualidade e a durabilidade do mesmo. É importante lembrar também que, os pesos mostrados devem ser DISTRIBUÍDOS ao longo de toda a área da peça.

FR: Veuillez faire attention aux poids maximums supportés par chaque produit du compartiment. Veuillez à ne pas dépasser ces poids, afin de garantir la qualité et la durabilité du produit. Il est également important de se rappeler que les poids indiqués doivent être RÉPARTIS sur toute la surface du rayon.

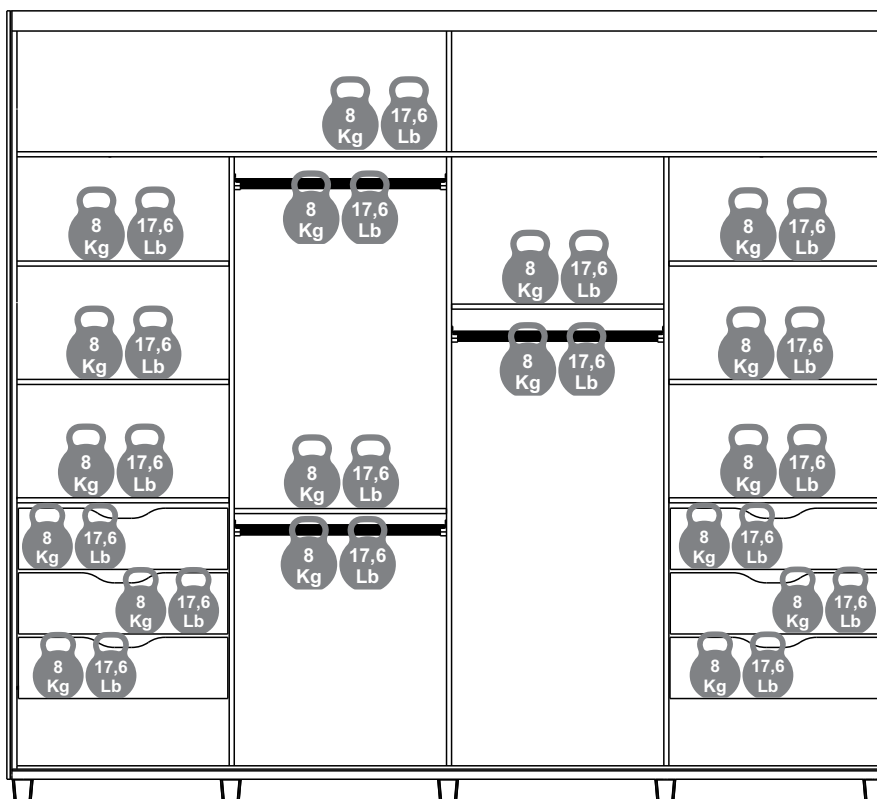



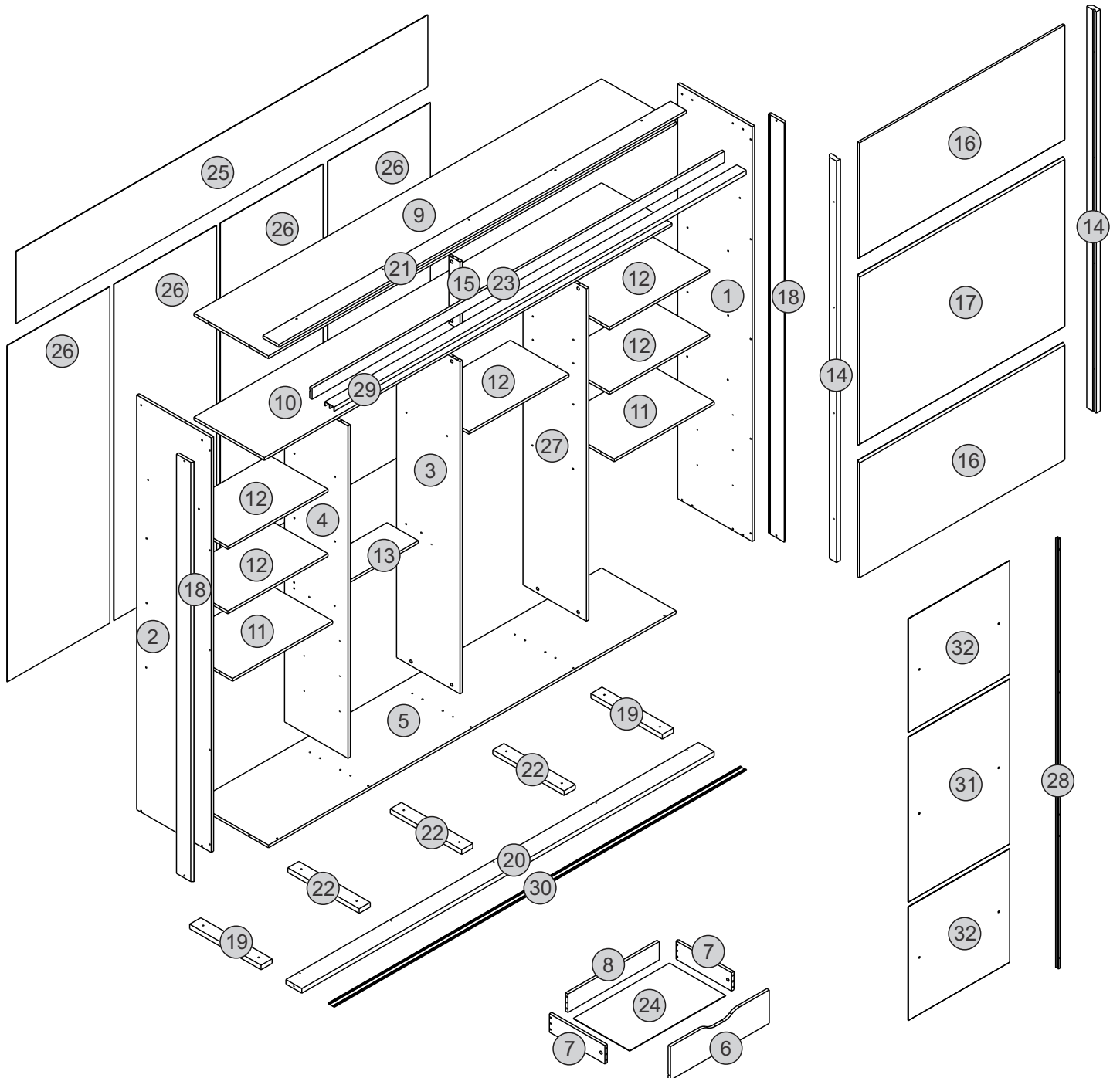







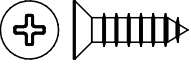
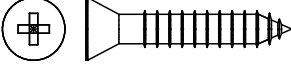
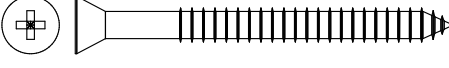

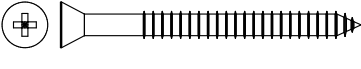
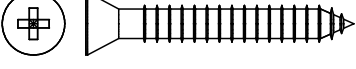
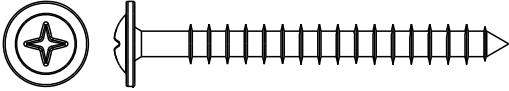



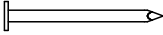
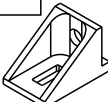

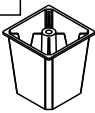

Conocer mejor las piezas de su producto
Getting to know your product parts better
Conhecendo melhor as peças do seu produto
Mieux connaître les pièces de votre produit

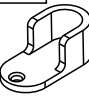

**Conocer mejor las piezas de su producto / Getting to know your product parts better
Conhecendo melhor as peças do seu produto / Mieux connaître les pièces de votre produit**

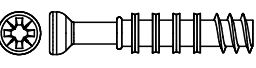
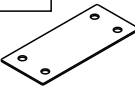
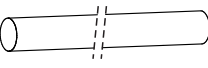
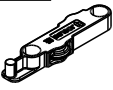



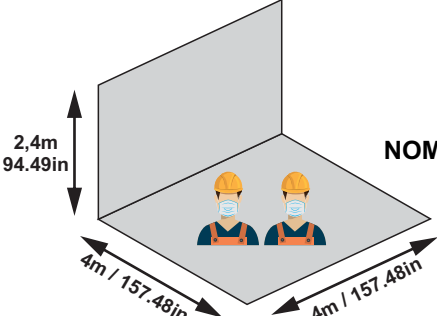

#	Ct. Qt.	Español	English	Português	Français	mm in
1	1	Lateral Derecha	Right Side	Lateral Direita	Coté Droit	2260 x 470 x 15 mm 88,97 x 18,50 x 0,59 in
2	1	Lateral Izquierda	Left Side	Lateral Esquerda	Coté Gauche	2260 x 470 x 15 mm 88,97 x 18,50 x 0,59 in
3	1	División Central	Center Division	Divisão Central	Séparateur Centrale	1811 x 400 x 15 mm 71,29 x 15,74 x 0,59 in
4	1	División Izquierda	Left Division	Divisão Esquerda	Séparateur Gauche	1811 x 400 x 15 mm 71,29 x 15,74 x 0,59 in
5	1	Base	Base	Base	Fond	2570 x 470 x 15 mm 101,18 x 18,50 x 0,59 in
6	6	Frente Cajón	Drawer Front	Frente de Gaveta	Façade Tiroir	623 x 182 x 15 mm 24,52 x 7,16 x 0,59 in
7	12	Lateral Cajón	Drawer Side	Lateral de Gaveta	Coté Droit et Gauche Tiroir	350 x 100 x 15 mm 13,77 x 3,93 x 0,59 in
8	6	Trasero Cajón	Drawer Back	Costa de Gaveta	Pièce Arrière Tiroir	576 x 100 x 15 mm 22,67 x 3,93 x 0,59 in
9	1	Tapa	Top	Tampo	Dessus de Tiroir	2570 x 470 x 15 mm 101,18 x 18,50 x 0,59 in
10	1	Tapa Intermedia	Intermediate Top	Tampo Intermediário	Dessus intermédiaire	2570 x 444 x 15 mm 101,18 x 17,48 x 0,59 in
11	2	Tapa Cajones	Drawer Top	Tampo Gavetas	Plafond Tirois	631 x 400 x 15 mm 24,84 x 15,74 x 0,59 in
12	5	Repisa	Shelf	Prateleira	Étagere	631 x 370 x 15 mm 24,84 x 14,56 x 0,59 in
13	1	Repisa Menor	Small Shelf	Prateleira Menor	Petit Étagere	631 x 197 x 15 mm 24,84 x 7,75 x 0,59 in
14	3	Manija	Handle	Puxador	Manche	2188 x 70 x 25 mm 86,14 x 2,76 x 0,98 in
15	1	Travesaño Divisoria	Divider Platter	Pilastra	Voie de Séparation	370 x 70 x 15 mm 14,56 x 2,75 x 0,59 in
16	4	Panel Menor Puerta	Small Door Panel	Painel Menor Porta	Panel Petit Porte	1295 x 635 x 12 mm 50,98 x 25 x 0,47 in
17	2	Panel Mayor Puerta	Large Door Panel	Painel Maior Porta	Panel Plus Grand Porte	1295 x 930 x 12 mm 50,98 x 36,61 x 0,47 in
18	2	Marco Lateral	Side Frame	Moldura Lateral	Cadre Latéral	2285 x 100 x 15 mm 89,96 x 3,93 x 0,59 in
19	2	Marco Lateral Inferior	Lower Side Frame	Moldura Lateral Inferior	Cadre Latéral Inférieur	450 x 70 x 25 mm 17,71 x 2,75 x 0,98 in
20	1	Marco Inferior	Lower Frame	Moldura Inferior	Cadre Inférieur	2600 x 100 x 25 mm 102,36 x 3,93 x 0,98 in
21	1	Marco Superior	Upper Frame	Moldura Superior	Cadre Supérieur	2570 x 100 x 15 mm 101,18 x 3,93 x 0,59 in
22	3	Zócalo Central	Center Baseboard	Rodapé Central	Socle Centrale	450 x 70 x 25 mm 17,71 x 2,75 x 0,98 in
23	1	Marco Delantero	Front Frame	Vista Frontal	Cadre Avant	2600 x 60 x 15 mm 102,36 x 2,36 x 0,59 in
24	6	Fondo Cajón	Drawer Bottom	Fundo de Gaveta	Fond Tiroir	606 x 355 x 2,5 mm 23,85 x 13,97 x 0,09 in
25	1	Costado Superior	Upper Back	Costa Superior	Pièce Arrière Supérieur	2596 x 392 x 2,5 mm 102,20 x 15,43 x 0,09 in
26	4	Costado Mayor	Larger Back	Costa Maior	Pièce Arrière Grand	1833 x 647 x 2,5 mm 72,16 x 25,47 x 0,09 in
27	1	División Derecha	Right Division	Divisão Direita	Séparateur Droit	1811 x 400 x 15 mm 71,29 x 15,74 x 0,59 in
28	1	Desempenador	Greater Straightener	Desempenador	Lisseur	2200 x 14,9 x 11 mm 86,61 x 0,58 x 0,43 in
29	1	Trillo Superior Aluminio	Aluminum Top Rail	Trilho Superior Alumínio	Sous-rail en Aluminium	2598 x 37,5 x 5,1 mm 102,28 x 1,47 x 0,20 in
30	1	Trillo Inferior Aluminio	Aluminum Bottom Rail	Trilho Inferior Alumínio	Sous-rail en Aluminium	2598 x 37,5 x 5,1 mm 102,28 x 1,47 x 0,20 in
31	1	Espejo Mayor	Larger Mirror	Espelho Maior	Grand Miroir	900 x 640 x 3mm 35,43 x 25,19 x 0,11 in
32	2	Espejo Menor	Small Mirror	Espelho Menor	Petit Miroir	620 x 640 x 3mm 24,40 x 25,19 x 0,11 in

Y estos son sus Accesorios
And these are your Accessories
E estes são os seus Acessórios
ET voici vos Accessoires

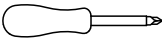
A  Ø3,5x14mm/0,16x0,55in (124x)	B  Ø4,0x25mm/0,15x0,98in (15x)	C  Ø4,0x50mm/0,16x1,97in (58x)	D  (6x)				
E  Ø3,0x40mm/0,11x1,57in (12x)	F  Ø4,0x35mm/0,15x1,37in (15x)	G  Ø4,5x50mm/0,17x1,97in (10x)	H  (2x)				
I  Ø6x30mm/0,24x1,18in (70x)	J  Ø6x50mm/0,24x1,97in (1x)	K  (160x)	L  (6x)	M  (2x)	N  (8x)	O  (10x)	
P  (60x)	Q  (1x)	R  (6x)	S  (6x)	T  (6x)	U  (1x)	V  (26x)	
X  (80x)	Y  (24x)	Z  (12x)	A1  (3x)	B1  (4x)	C1  (2x)	D1  (4x)	E1  (50x) (60x)

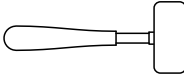
F1  Ø4,0x12mm/0,16x0,47in (48x)	 <p>NÚMERO DE PERSONAS Y ÁREA DE ARMADO NUMBER OF PEOPLE AND ASSEMBLY AREA NÚMERO DE PESSOAS E ÁREA DE MONTAGEM NOMBRE DE PERSONNES ET ZONE DE RASSEMBLEMENT</p>
---	--

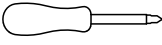
HERRAMIENTAS NECESARIAS / TOOLS REQUIRED / FERRAMENTAS NECESSÁRIAS / OUTILS NÉCESSAIRES

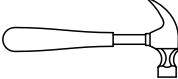
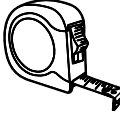
				<p>ES: NO UTILICE UN DESTORNILLADOR ELÉCTRICO O A BATERÍADO EN: NOT USE A BATTERY OR ELECTRIC SCREWDRIVER PT: NÃO UTILIZE PARAFUSADEIRA ELÉTRICA OU À BATERIA FR: NE PAS UTILISER DE TOURNEVIS ÉLECTRIQUE OU À BATTERIE</p>
				
				

Y si lo necesitas, mide en la regla al lado
 And if you need to, measure on the ruler beside
 E se precisar, meça na régua ao lado
 ET si vous en avez besoin, mesurez sur la règle à côté

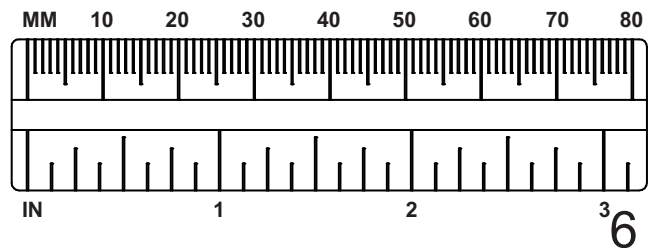

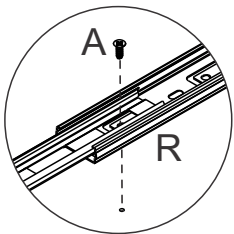
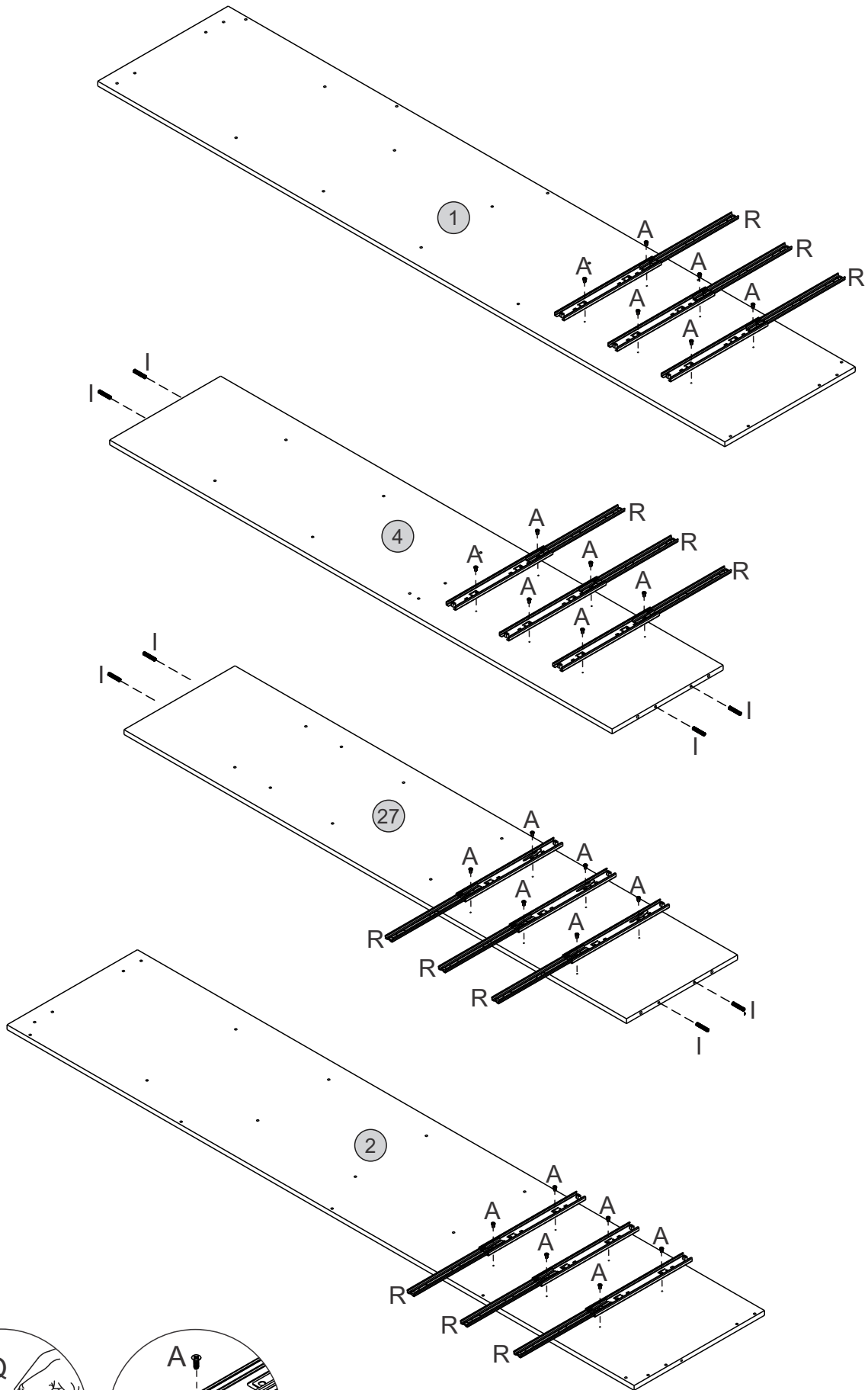

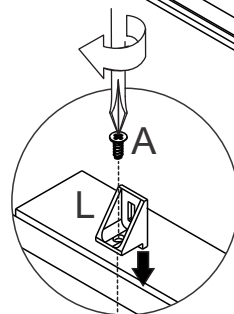
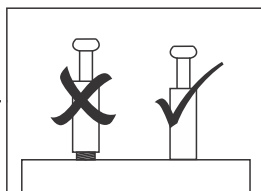
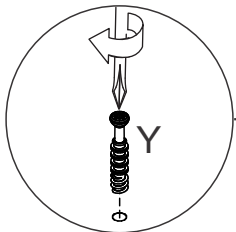
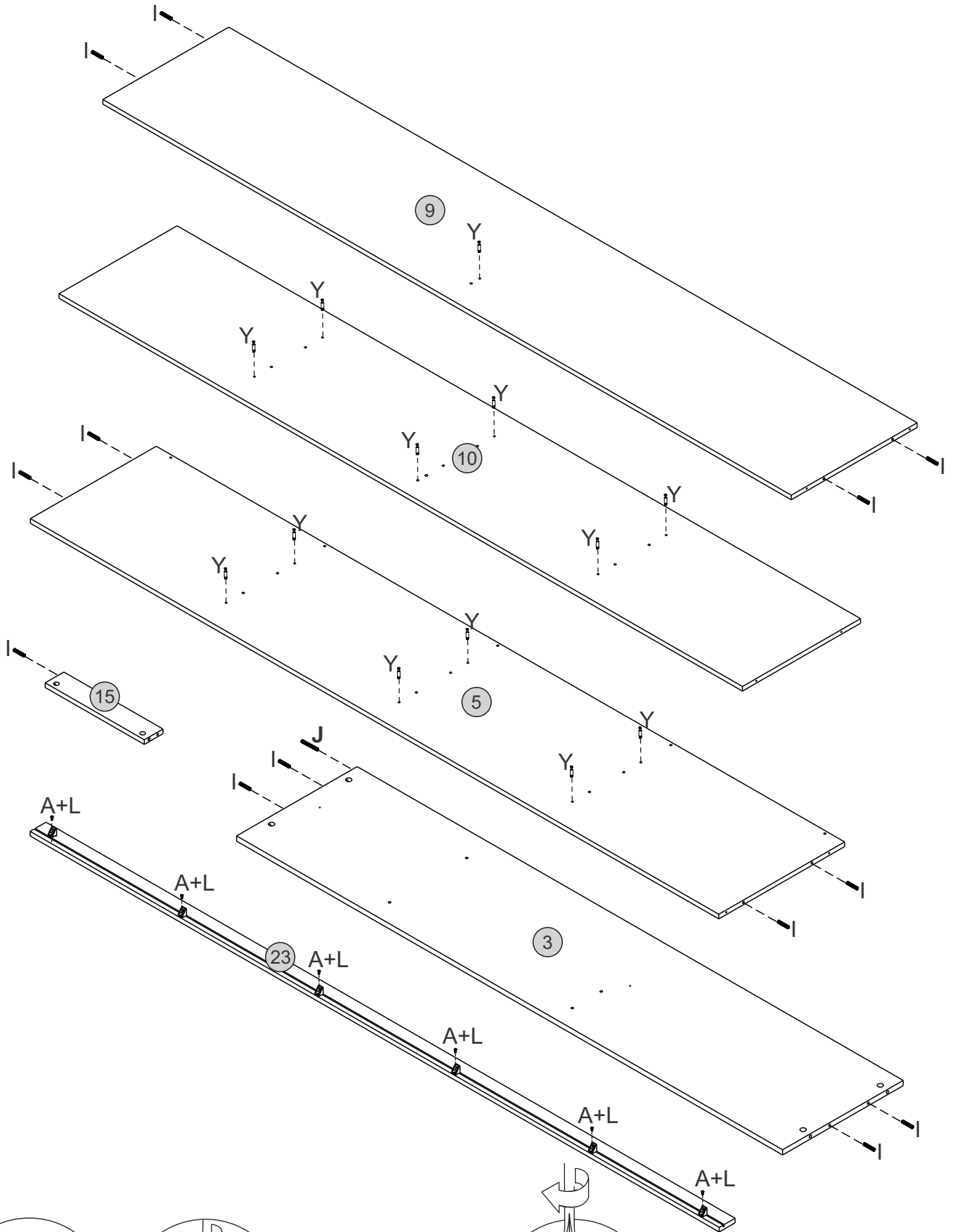

3

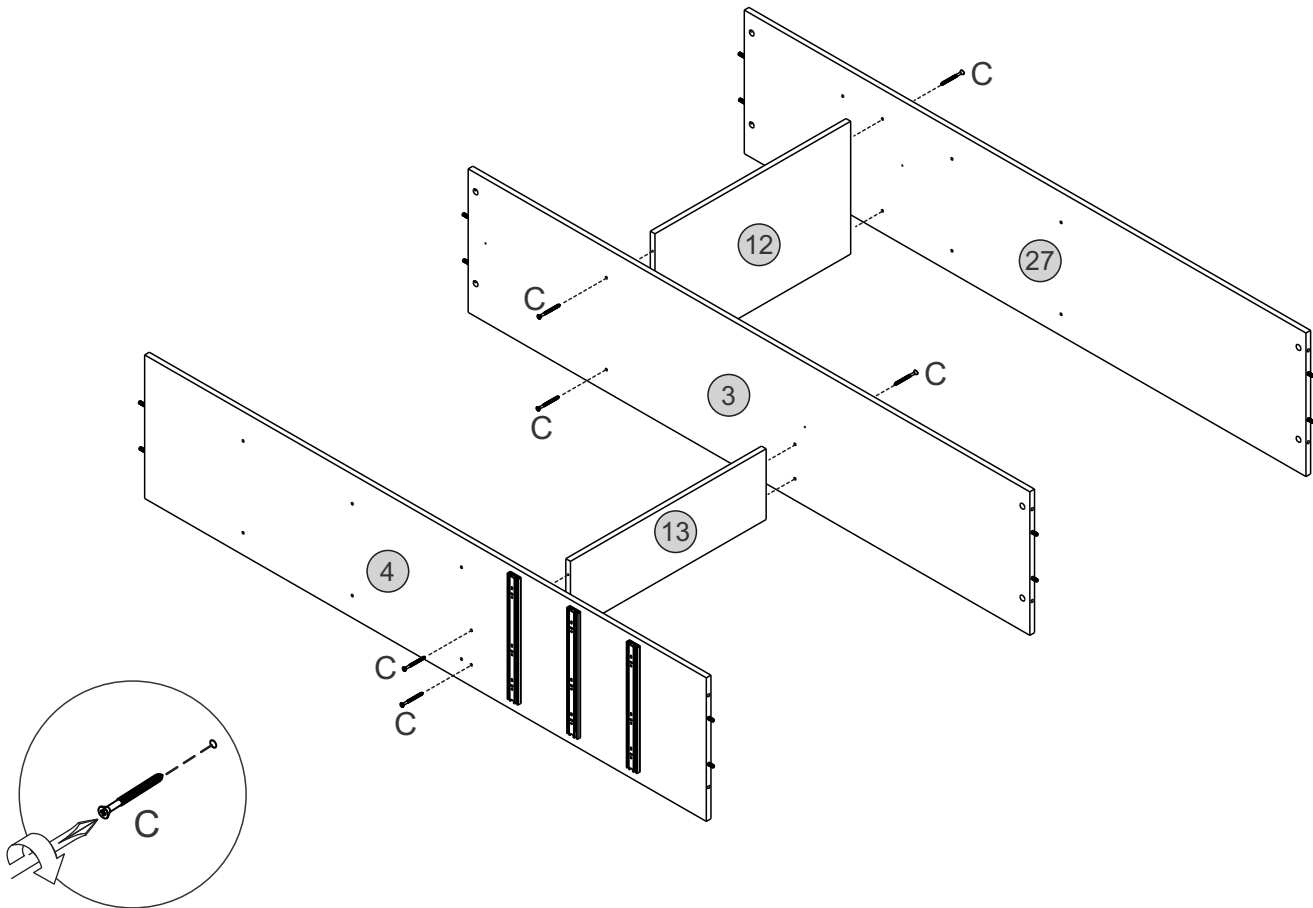

4

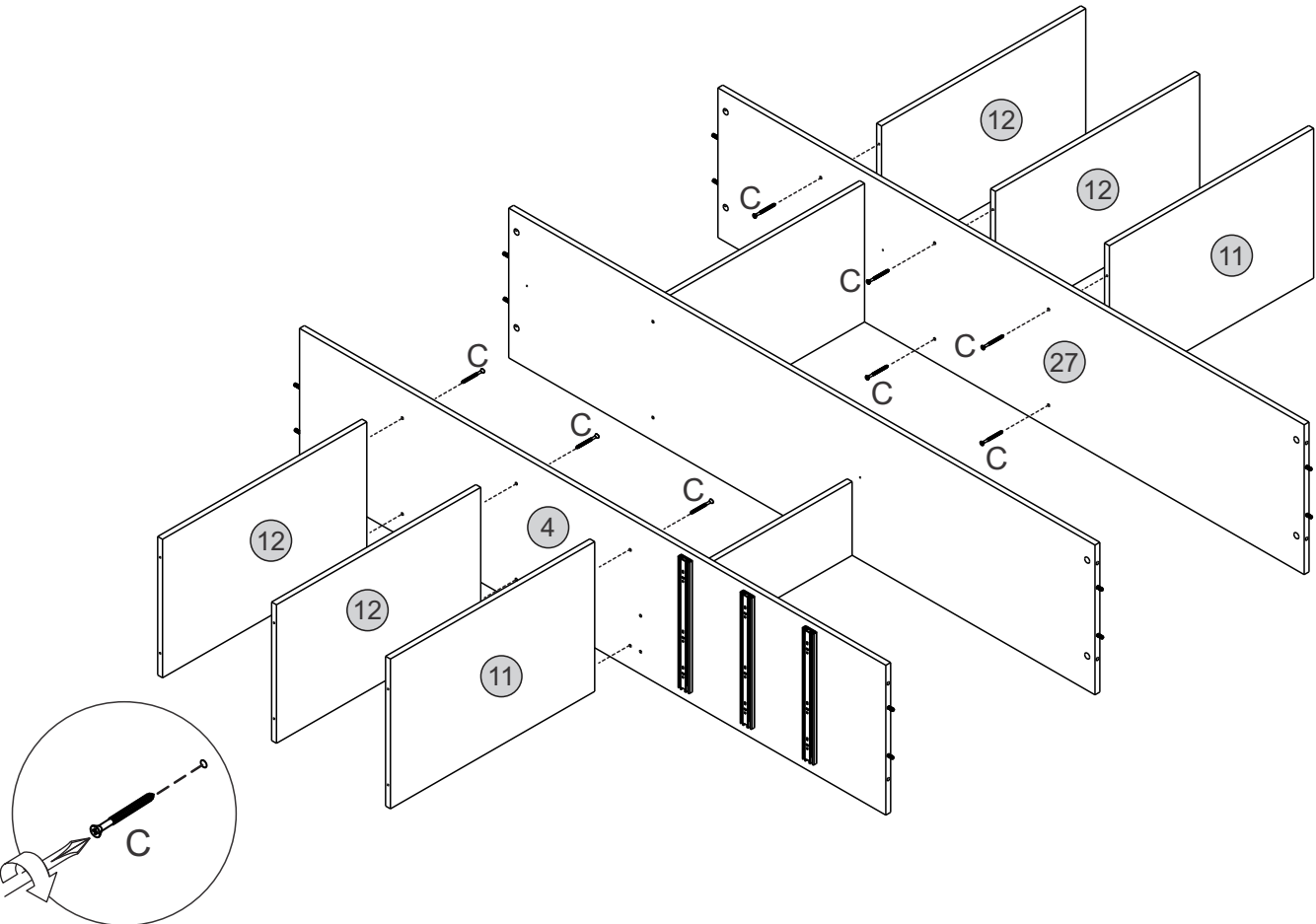

5

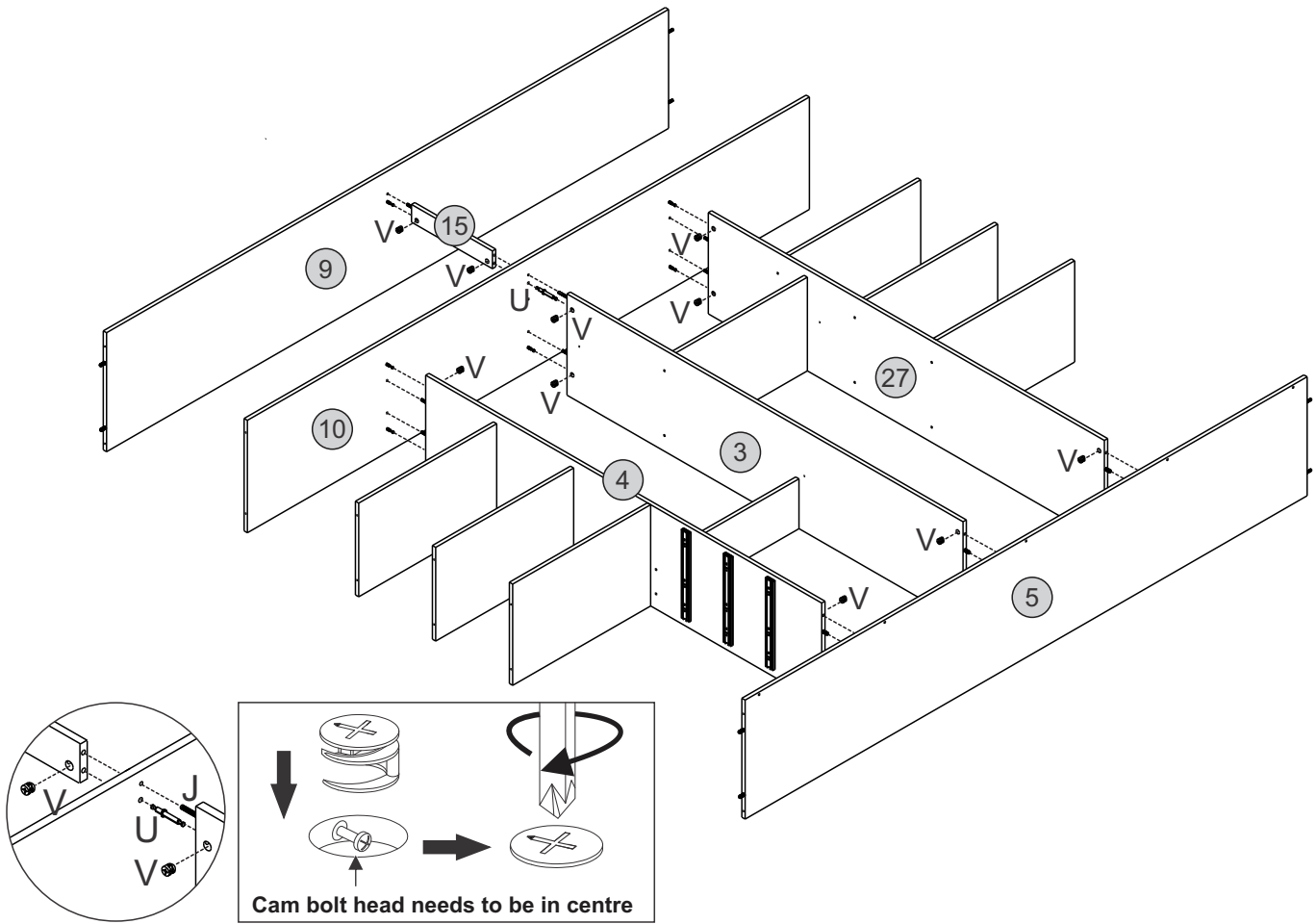

6

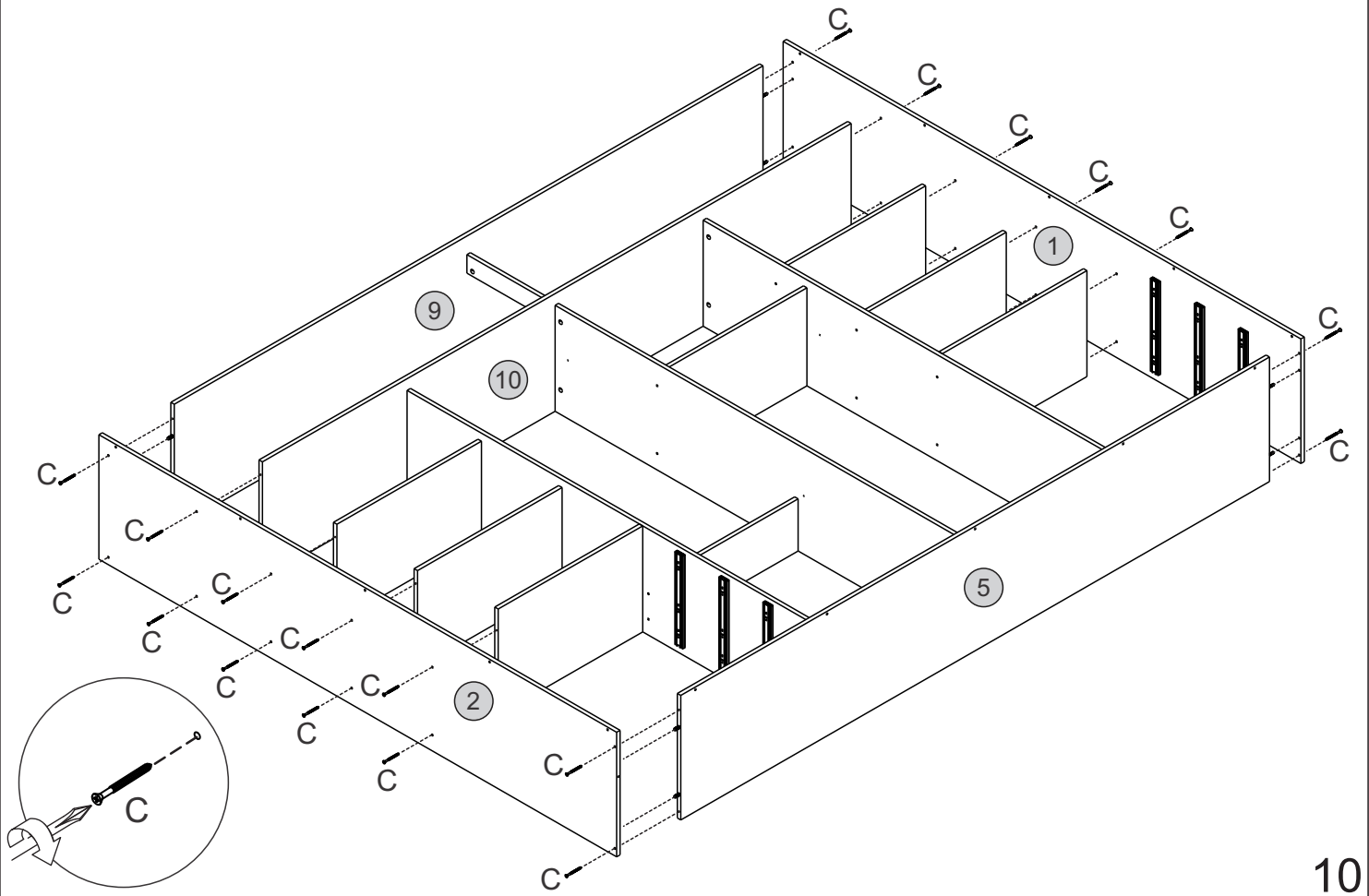

7

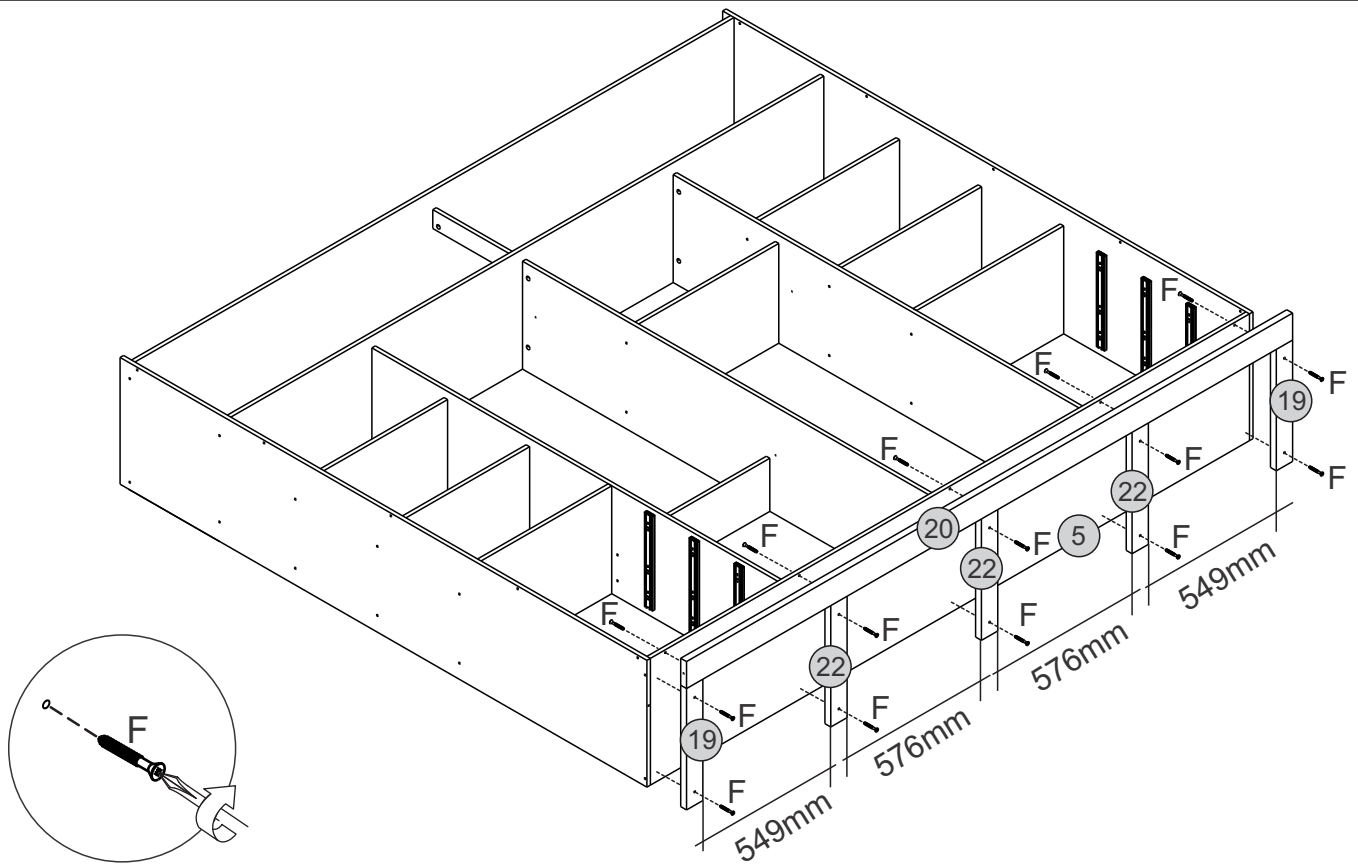

8

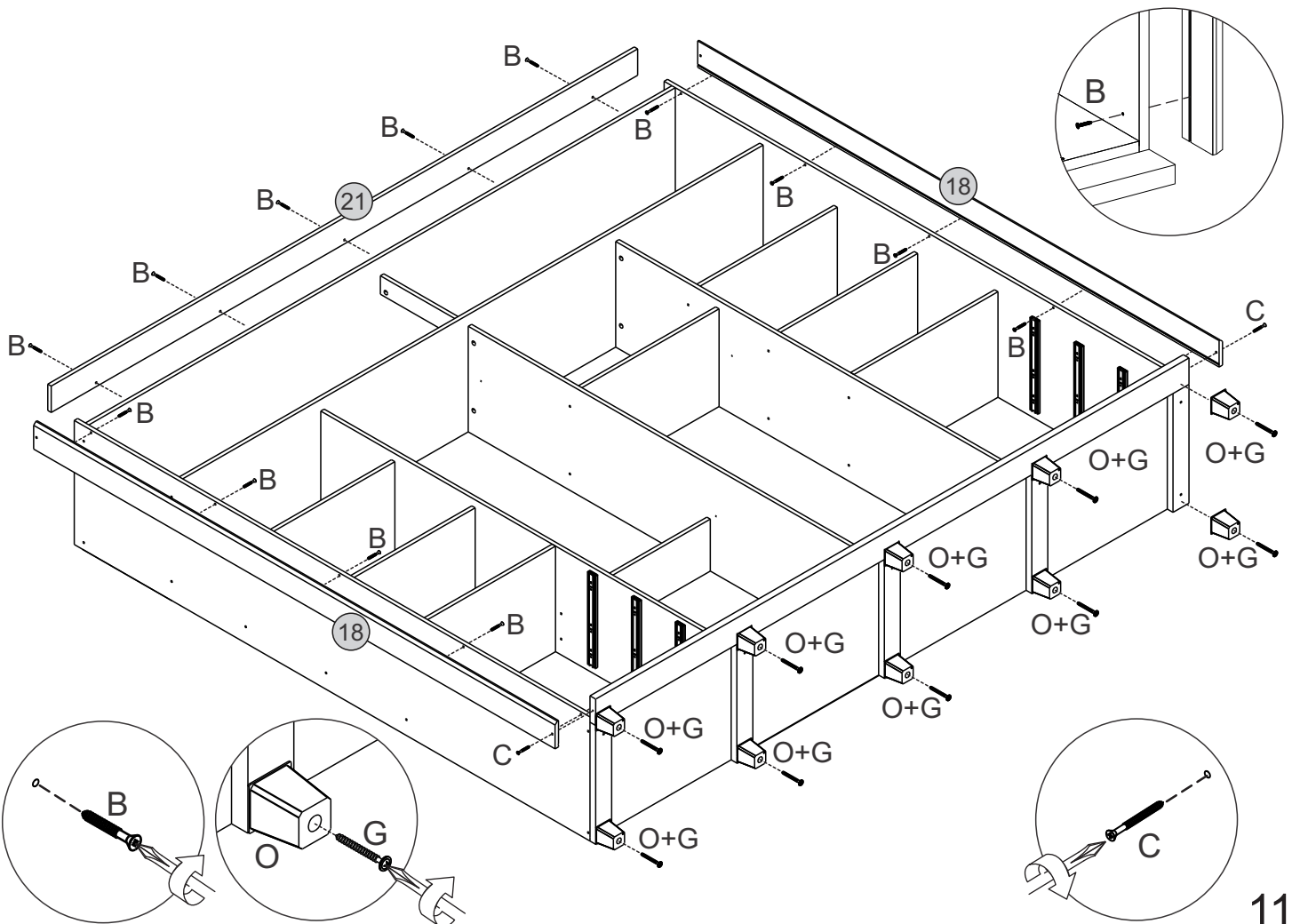

11

9

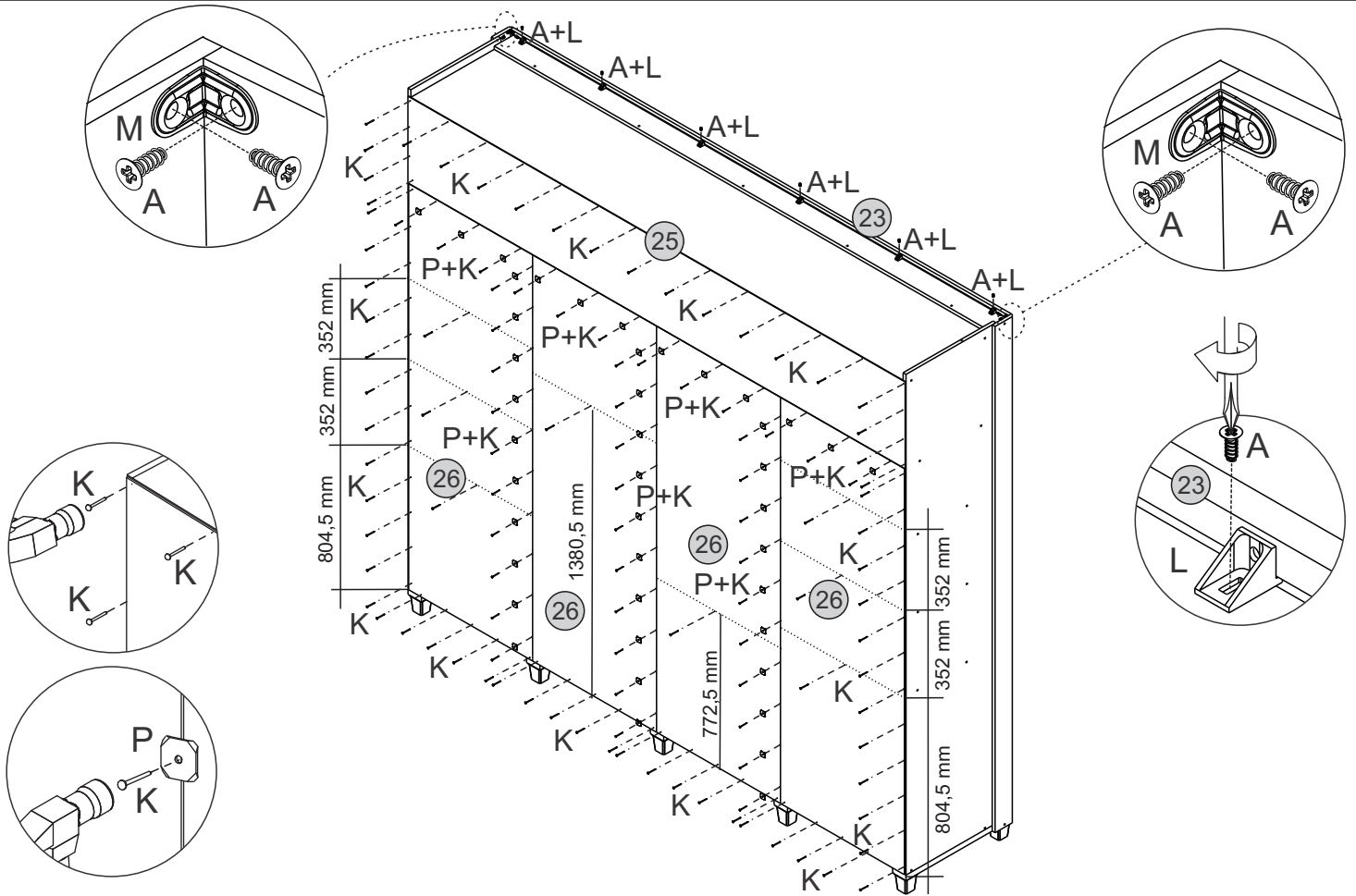

10

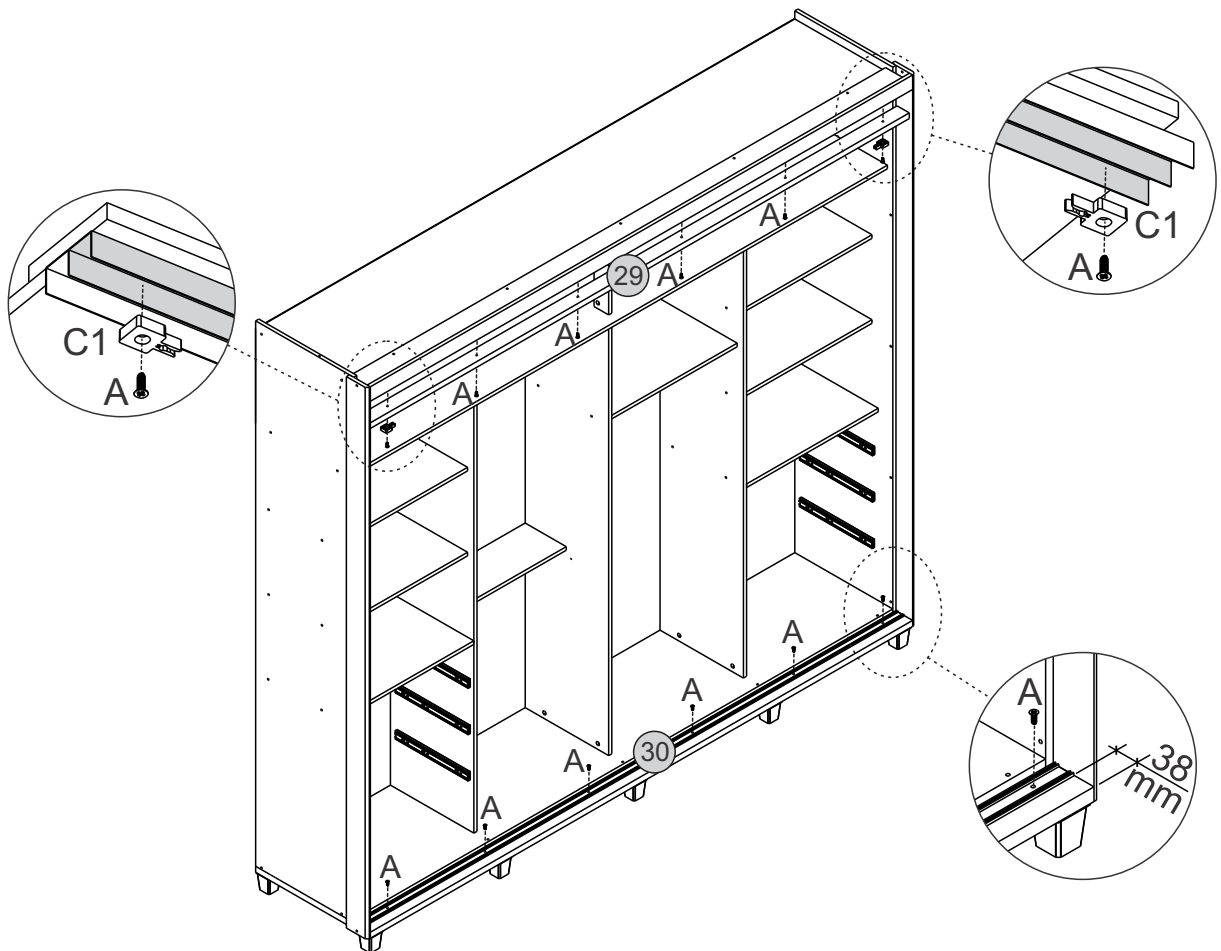

11

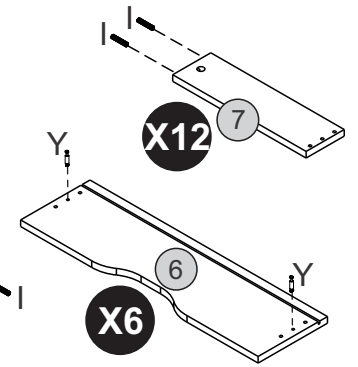
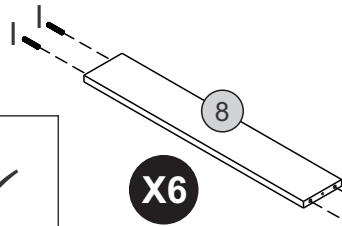
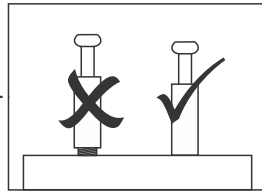
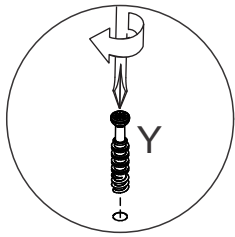

12

6x

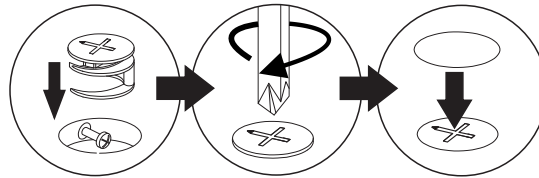
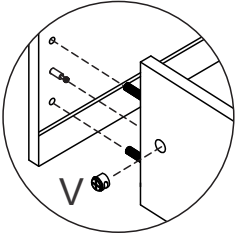
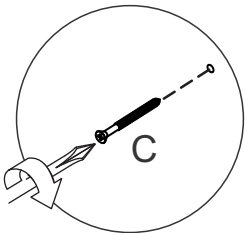
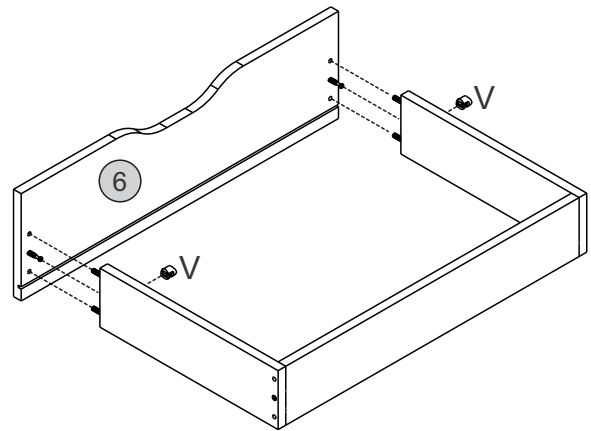
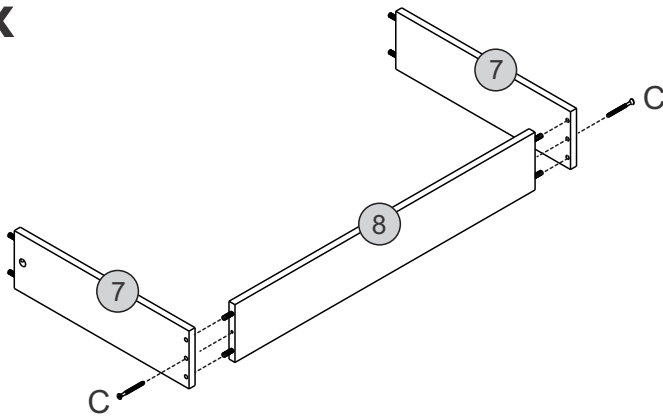

13

6x

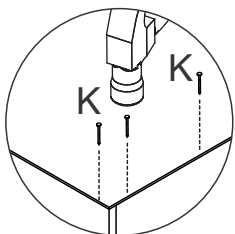
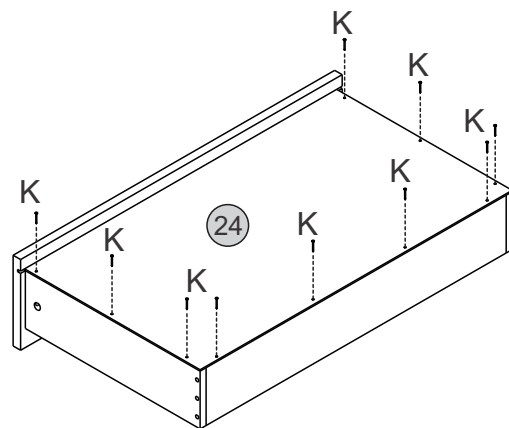
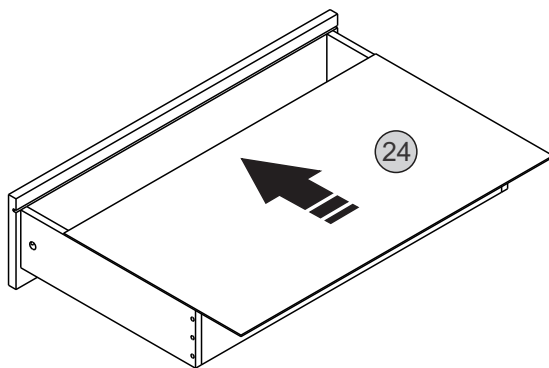

14

6x

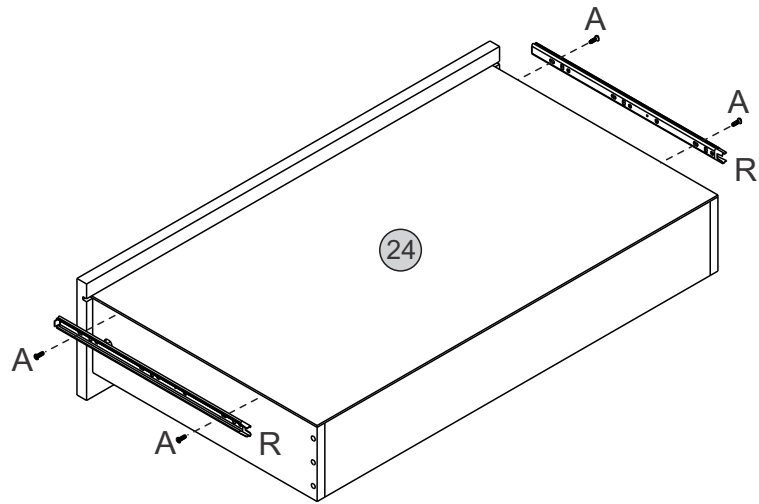
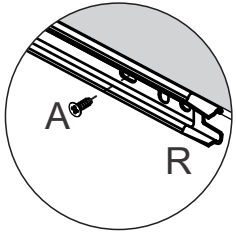
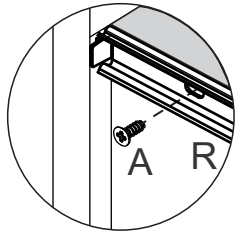

15

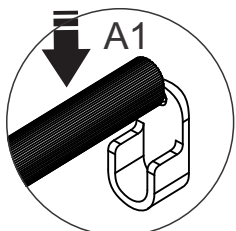
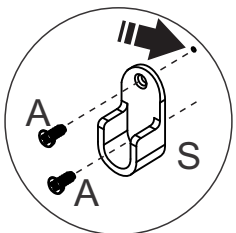
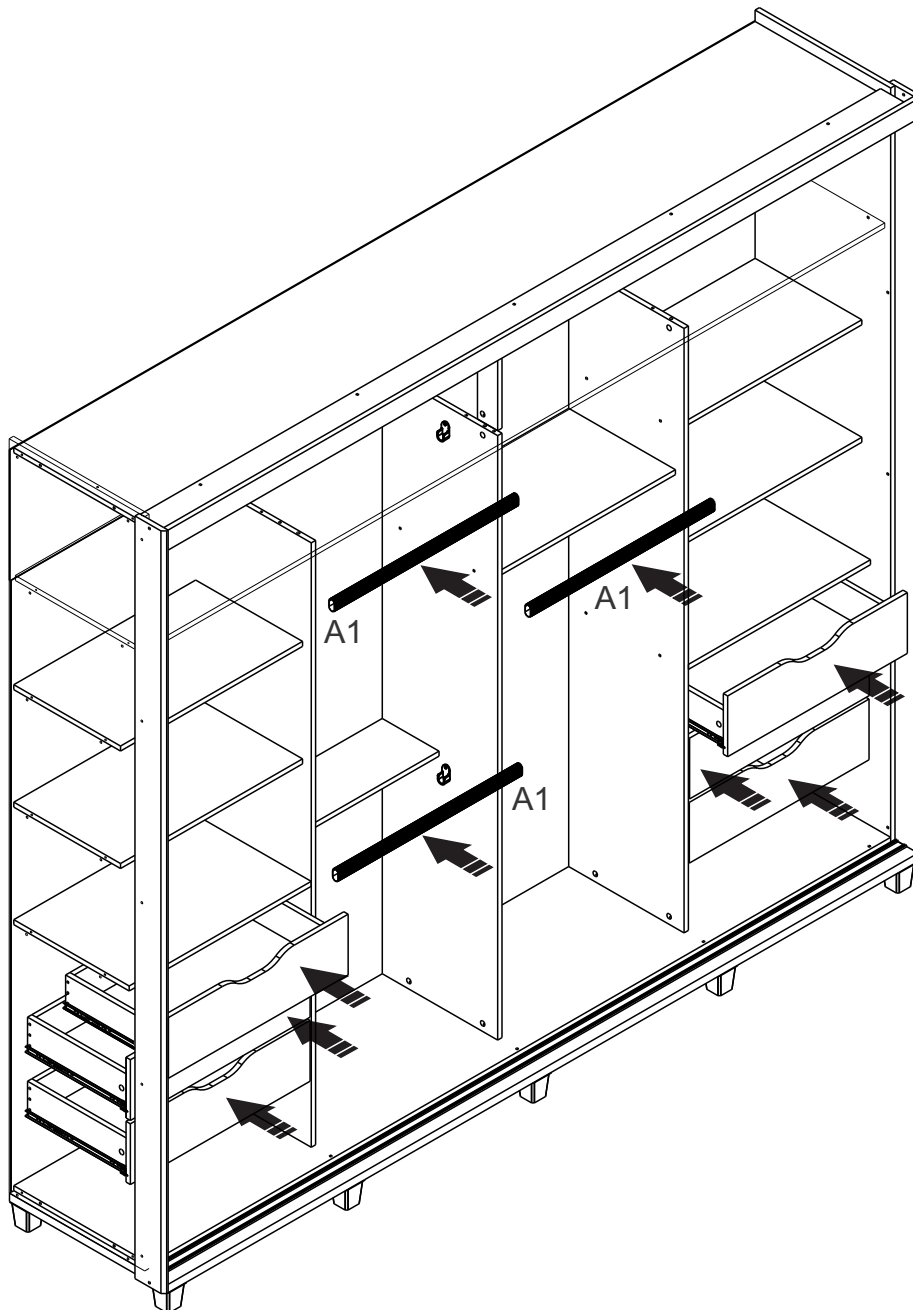

16

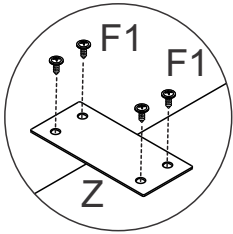
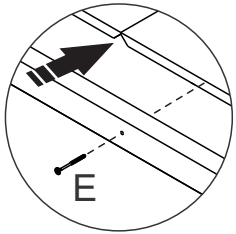
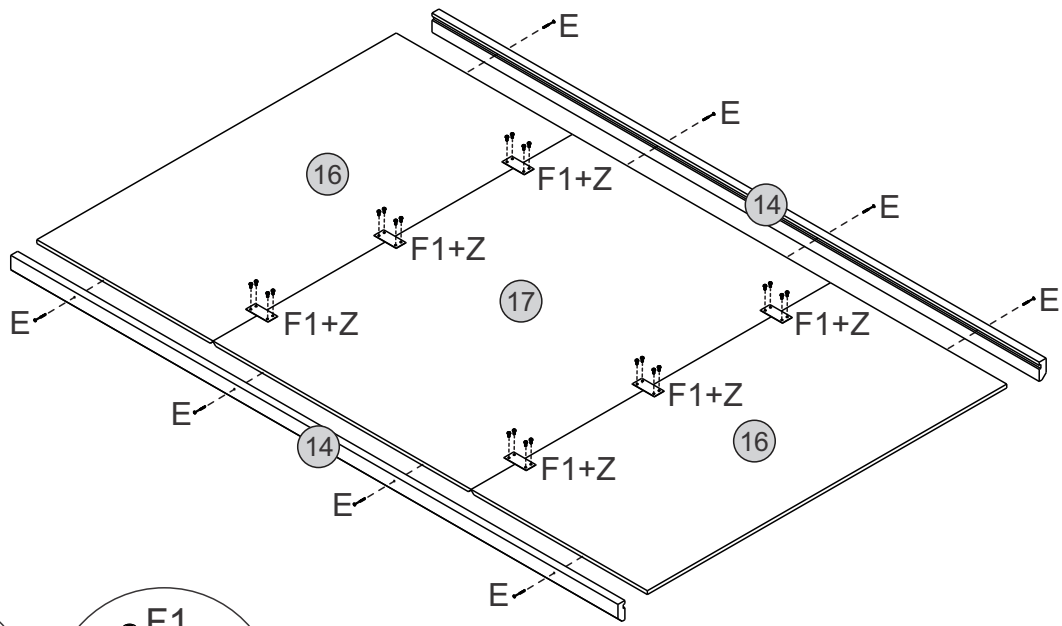

17

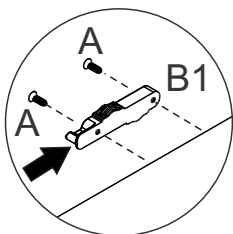
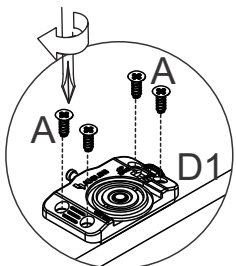
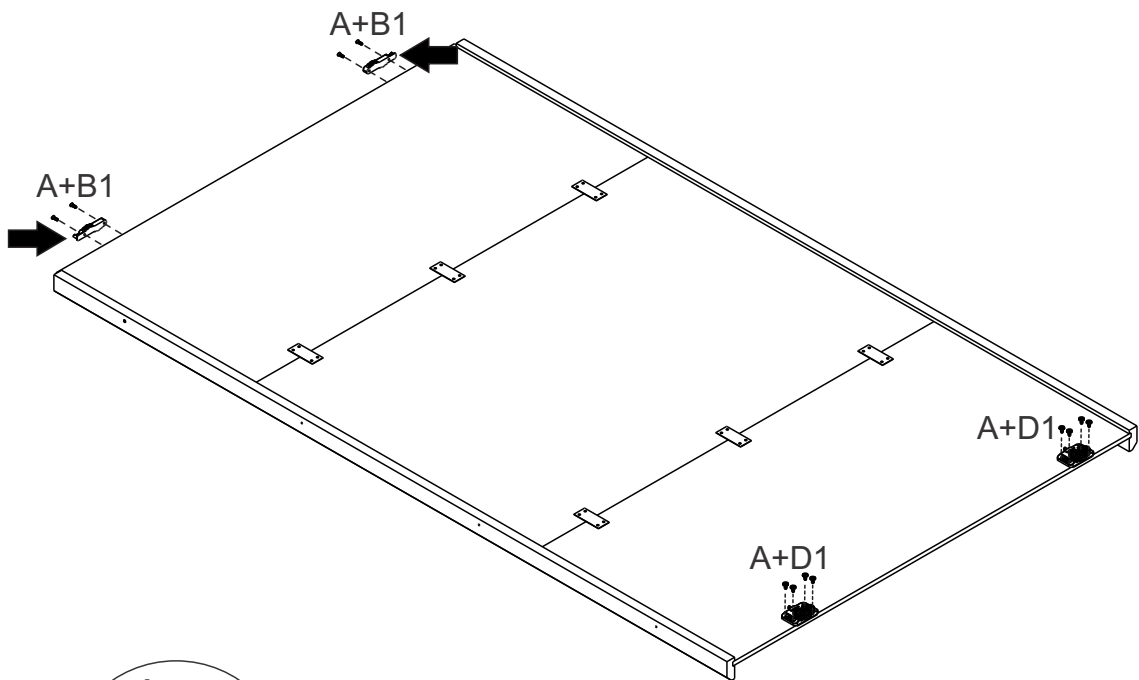

18

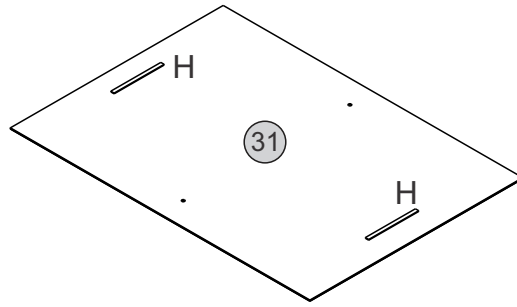
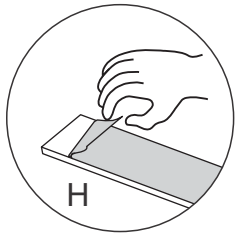

19

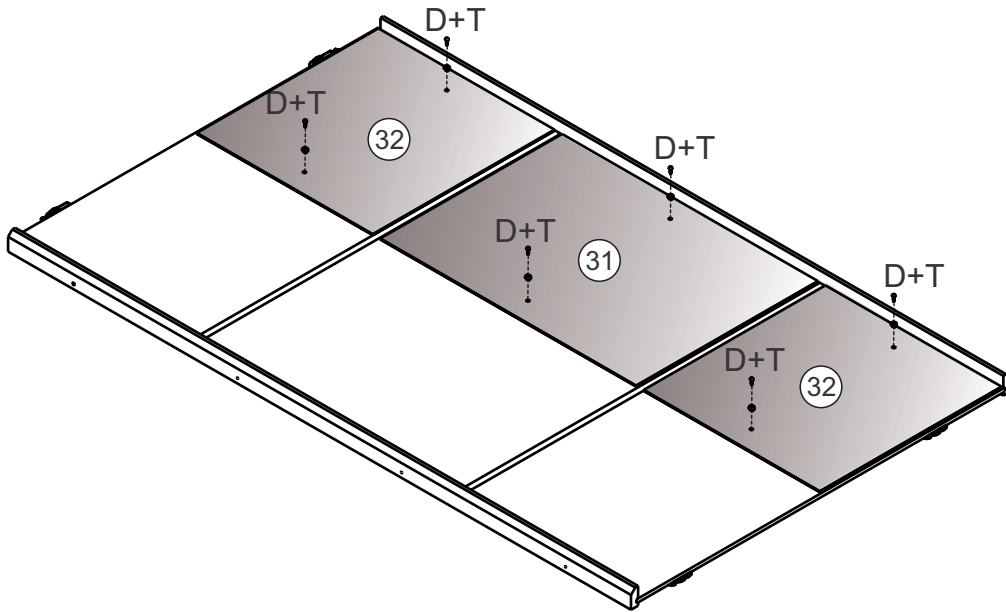
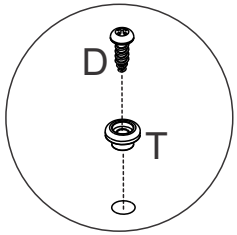

20

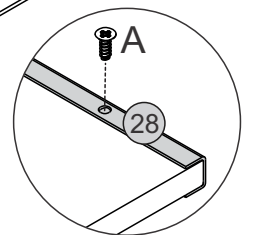
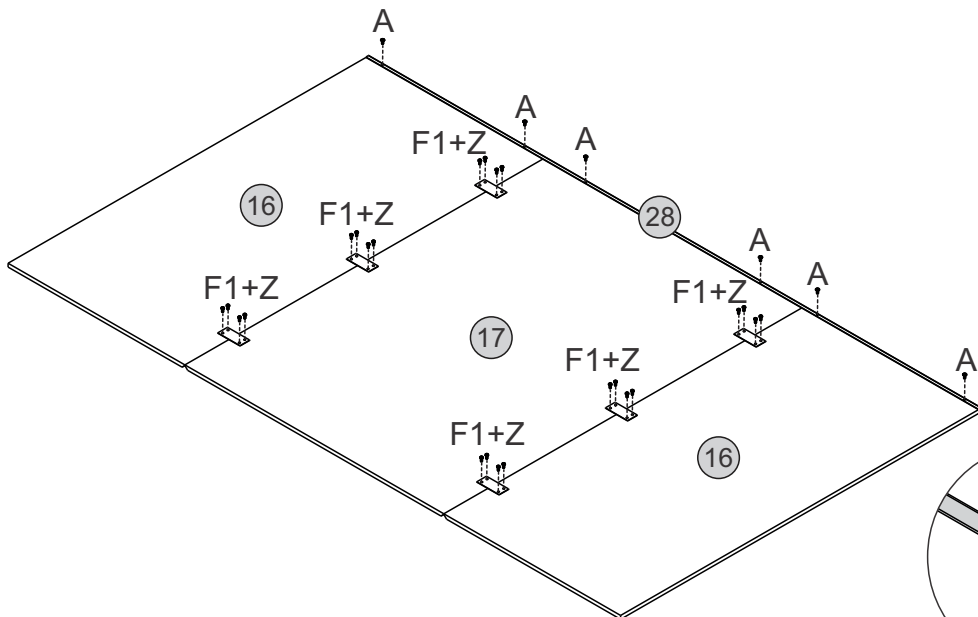
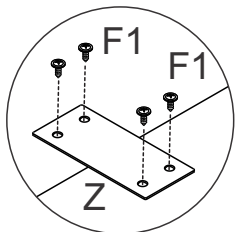

21

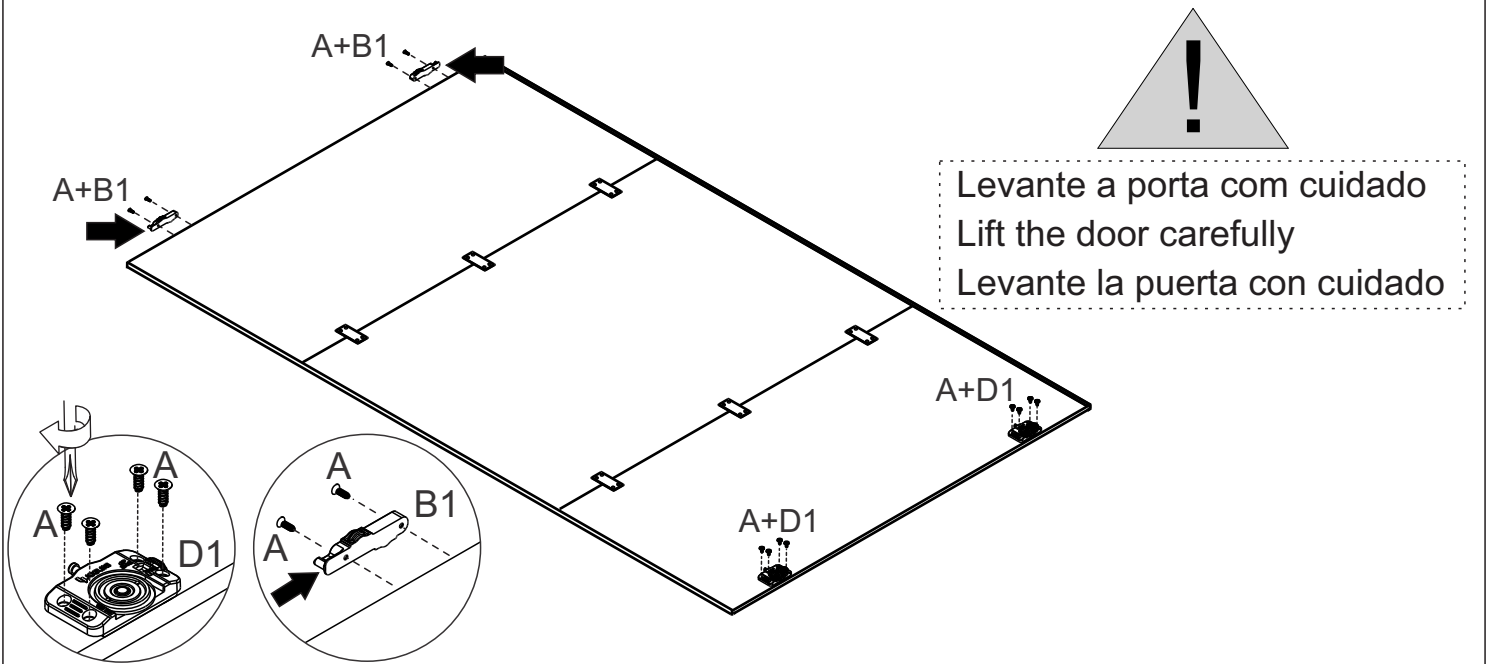

22

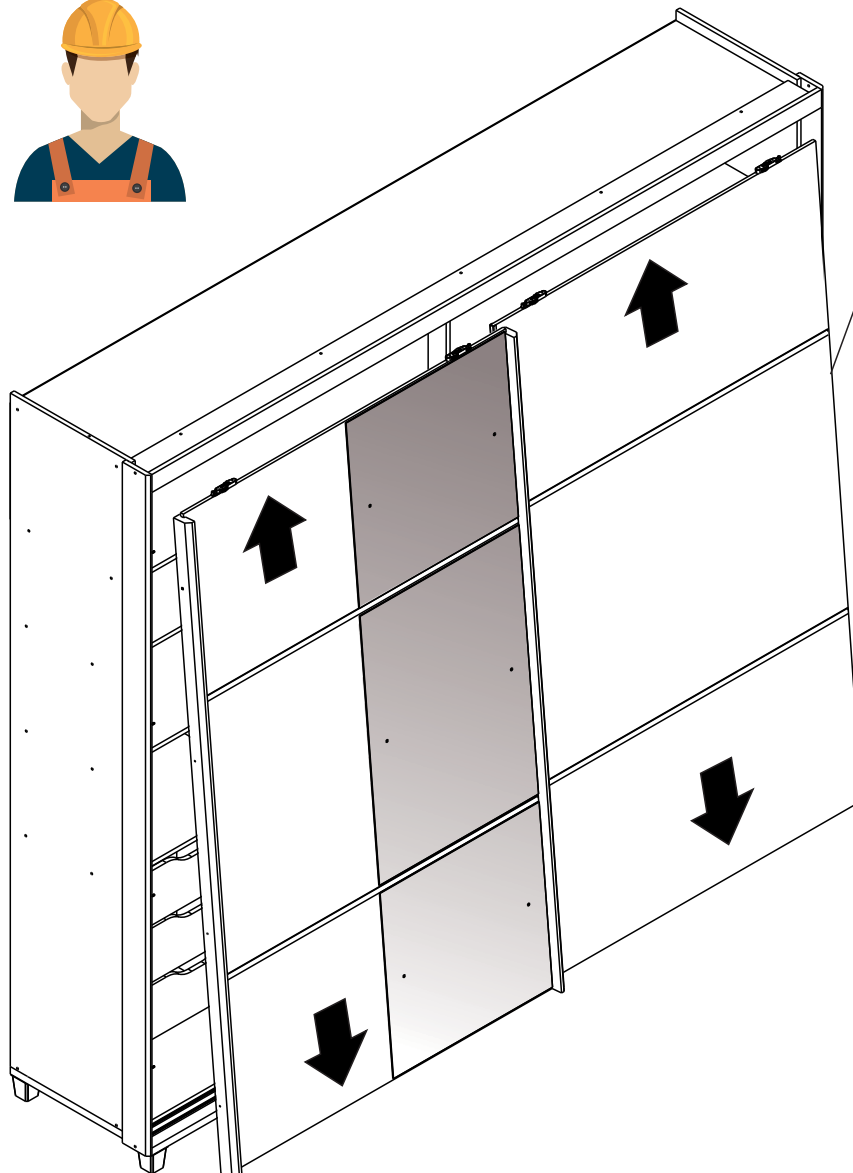

Atenção!
Lado sem desempenador
Attention!
Side without straightener
Atención!
Lado sin alisador

23

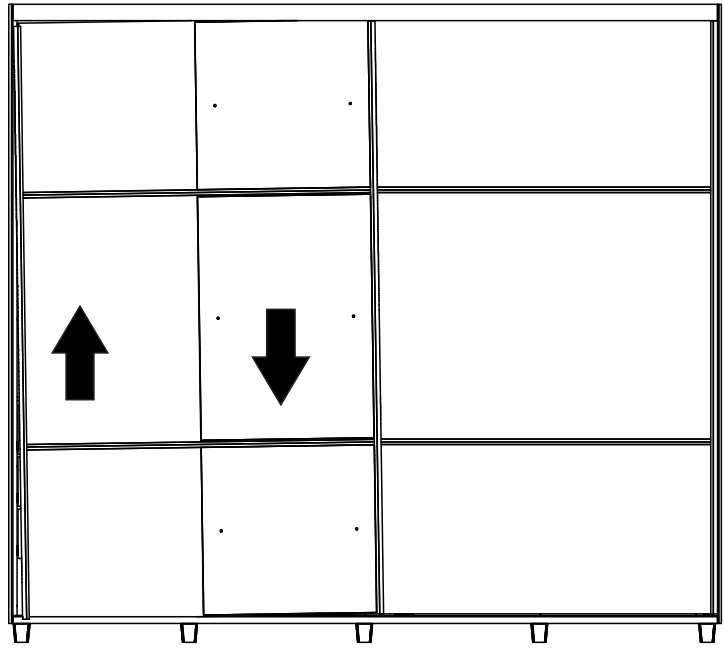
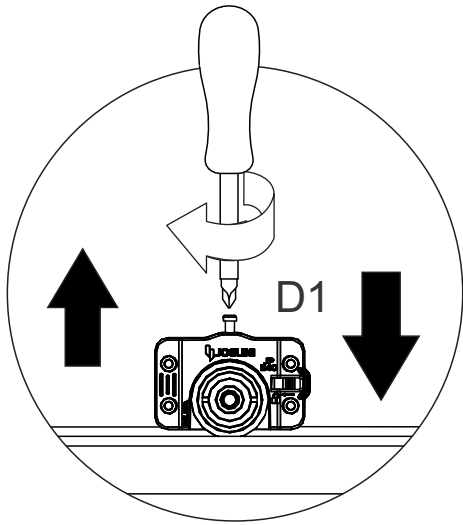

24

