



CARRARO  
MÓVEIS

Rua Nelson Carraro, 2001 - Bento Gonçalves - Rio Grande do Sul -Brasil - Cep: 95702-798  
Fone: (55) 54 3455 12 12 - www.carraro.com.br - Cód. Manual: 12000683 - Rev. 02

# Ref. 835

Ropero 2 Puertas Correderas 2 Cajones / 2-Sliding Door 2-Drawer Wardrobe / Roupeiro 2 Portas Correr 2 Gavetas

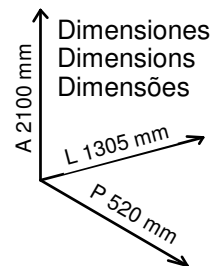
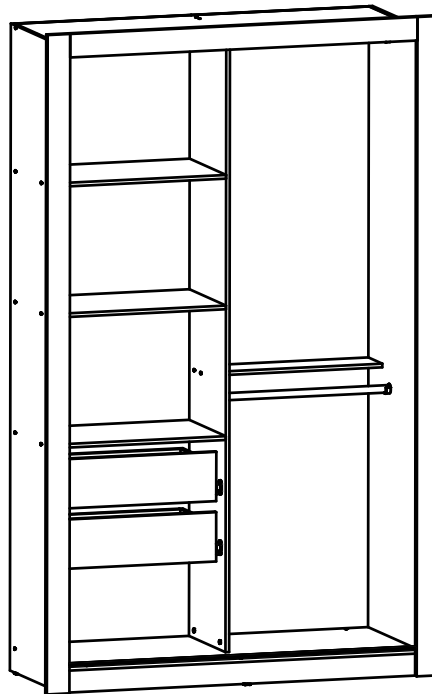
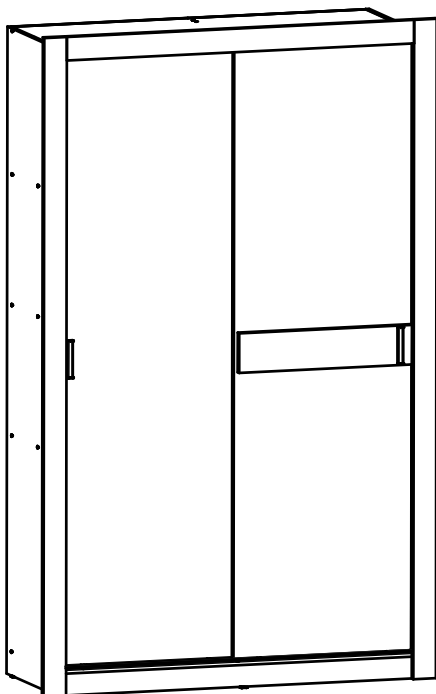

<b>(A)</b>  Parafuso 4 x 12   106 un.	<b>(B)</b>  Parafuso 4 x 14   24 un.	<b>(C)</b>  Parafuso 3,5 x 19   4 un.	<b>(D)</b>  Parafuso 4 x 20   2 un.	<b>(E)</b>  Parafuso 4 x 25   6 un.	<b>(F)</b>  Parafuso 4,0 x 50   32 un.
<b>(G)</b>  6 x 30   20 un.	<b>(H)</b>  24 un.	<b>(I)</b>  69 un.	<b>(J)</b>  2 un.	<b>(K)</b>  2 un.	<b>(L)</b>  13 un.
<b>(M)</b>  10 un.	<b>(N)</b>  6 un.	<b>(O)</b>  2 un.	<b>(P)</b>  8 un.	<b>(Q)</b>  10 un.	<b>(R)</b>  4 un.
<b>(S)</b>  2 un.	<b>(T)</b>  4 un.	<b>(U)</b>  4 un.	<b>(V)</b>  1 un.	<b>(W)</b>  8 un.	
<b>(X)</b>  20 un.    16 un.					

Herramientas  
Tools  
Ferramentas



90 min.



Personas Necesarias  
People Required  
Pessoas Necessárias

2



### Consejos de Conservación

- No debe utilizarse en la limpieza, abrasivos como lana de acero, alcohol, vinagre, limón, o productos corrosivos que puedan rayar o quitar la película protectora en los muebles.
- Cuando la limpieza de muebles en general, napa y formica, deben utilizarse un paño ligeramente humedecido y jabón suave.
- Para mover el móvil, es importante que este se eleve desde el suelo, debido a que el arrastre puede causar daño estructural.
- No deje a su móvil en exposición a la intemperie.

### Conservation Tips

- Do not use abrasive products to clean such as steel wool, alcohol, vinegar, lemon, scouring powder, or corrosive products which can scratch or peel off the protective film of the furniture.
- The best way to clean your furniture is to use a slightly moistened cloth with a mild soap.
- To move the furniture assembled, it is important that it is lifted off the ground, because the drag it can cause structural damage.
- Do not leave your furniture in weather exposure.

### Dicas de Conservação

- Não utilizar na limpeza produtos abrasivos tais como: palha de aço, álcool, vinagre, limão, saponáceo, ou produtos corrosivos que possam riscar ou descolar a película protetora dos móveis.
- Na limpeza de móveis em geral, napa e fórmicas, deve ser utilizado um pano levemente umedecido e sabão neutro.
- Para a movimentação do móvel, é importante que este seja levantado do chão, pois ao arrastá-lo pode causar avarias estruturais.
- Não deixe o móvel em exposição a intempéries.

### Certificado de Garantia

A garantia dos produtos fabricados pela Carraro, abrange eventuais defeitos/vícios de fabricação, no prazo estabelecido pelo Código de Defesa do Consumidor, em seu artigo 26,II, o qual prevê a garantia legal de 90 (noventa) dias.

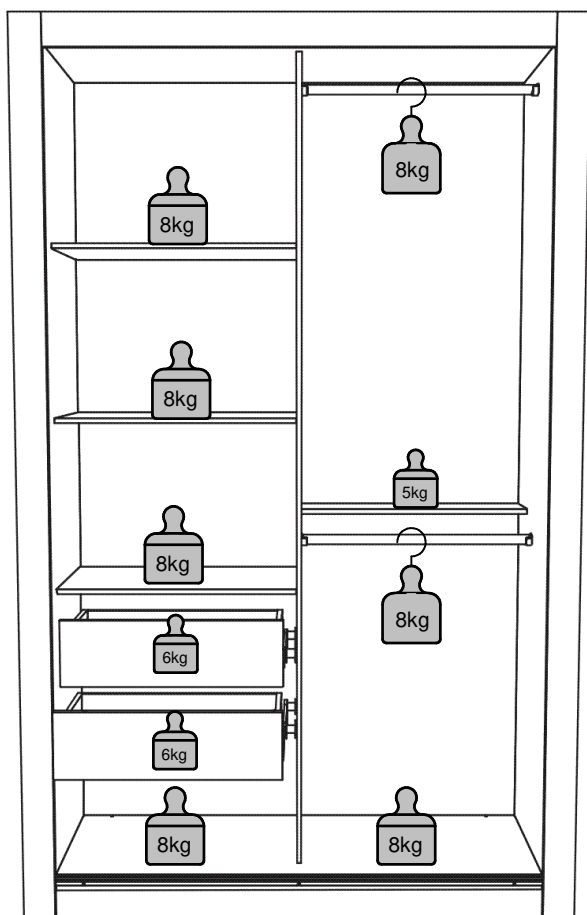

#### Peso por estante

Por favor, preste atención a los pesos máximos admitidos por cada compartimento del producto. Tenga cuidado de no exceder estos pesos, con el fin de garantizar la calidad y durabilidad del producto. Es importante recordar que los pesos muestran en caso de ser distribuida en toda el área de la plataforma.

#### Weight per shelf

Please pay attention to the maximum weights supported by each compartment product. Be careful not to exceed these weights, in order to ensure the quality and durability of the product. It is important to remember also that the weights shown should be distributed throughout the area of the shelf.

#### Peso por Prateleira

Ao lado são demonstrados os pesos máximos suportados por cada compartimento do produto. Cuide para não exceder esses pesos, afim de garantir a qualidade e a durabilidade do mesmo. É importante lembrar também, que os pesos mostrados devem ser DISTRIBUÍDOS ao longo de toda a área da peça.

LISTA DE PIEZAS / LIST OF PARTS / RELAÇÃO DE PEÇAS

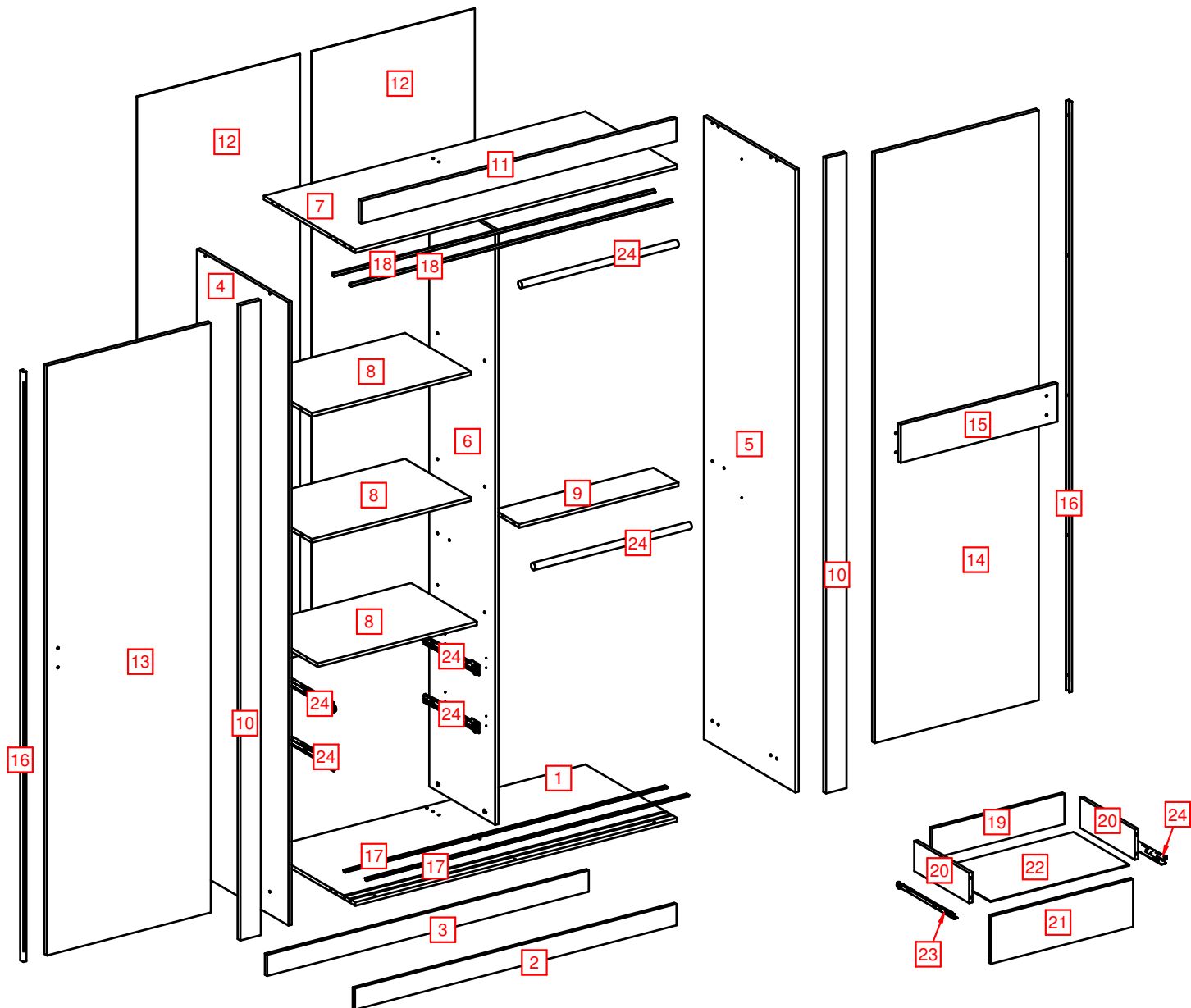

#	Qtde.	Espanhol	Inglés	Português	Dimensões	#	Qtde.	Espanhol	Inglés	Português	Dimensões
1	1	Base	Base	Base	1178 x 500 x 12	14	1	Puerta Corred. Central	Central Sliding Door	Porta Correr Central	1950 x 600 x 15
2	1	Rodapié Delantero	Front Baseboard	Rodapé Dianteiro	1178 x 70 x 12	15	1	Detalle Puerta Central	Central Door Detail	Detalhe Porta Central	574 x 126 x 15
3	1	Rodapié Trasero	Back Baseboard	Rodapé Traseiro	1178 x 70 x 12	16	2	Enderezador	Straightner	Desempenador	1950 x 18,5 x 11
4	1	Lateral Izquierda	Left Side	Lateral Esquerda	2060 x 500 x 12	17	2	Trilho Inferior	Lower Profile	Trilho Inferior	Compr. 1177mm
5	1	Lateral Derecha	Right Side	Lateral Direita	2060 x 500 x 12	18	2	Trilho Superior	Upper Profile	Trilho Superior	Compr. 1177mm
6	1	División	Division	Divisão	1965 x 360 x 12	19	2	Costado Cajón	Drawer Back	Costa de Gaveta	484 x 100 x 12
7	1	Tapa	Top	Tampo	1178 x 500 x 12	20	4	Lateral de Cajón	Drawer Side	Lateral de Gaveta	300 x 100 x 12
8	3	Tapa Cajones	Drawers Top	Tampo Gavetas	583 x 360 x 12	21	2	Frente de Cajón	Drawer Front	Frente de Gaveta	520 x 157 x 12
9	1	Estante Reducida	Smaller Shelf	Prateleira Reduzida	583 x 137 x 12	22	2	Fondo Cajón	Drawer Bottom	Fundo de Gaveta	508 x 305 x 2,8
10	2	Marco Lateral	Side Frame	Moldura Lateral	2100 x 75 x 15	23	2	Corredera Metalica	Metallic Runner	Correção Metálica	Compr.: 300mm
11	1	Marco Superior	Upper Frame	Moldura Superior	1154 x 75 x 15	24	2	Rolizo Percha	Hanger Rod	Cabideiro	Ø23 x 573
12	2	Costado	Back	Costa	1989 x 597 x 2,8						
13	1	Puerta Corred. Lateral	Side Sliding Door	Porta Correr Lateral	1950 x 600 x 15						

1

Plástico no tampo  
Plástico en la parte superior  
Plastic on top

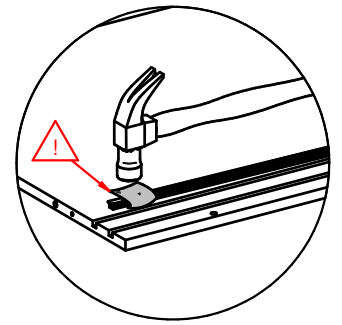

Não bata diretamente,  
utilize proteção entre o  
martelo e o perfil.

No golpee directamente,  
use protección entre el  
martillo y el perfil.

Do not hit directly,  
use protection between  
the hammer and the profile.

Alumínio na base  
Aluminio en la base  
Aluminum at the base

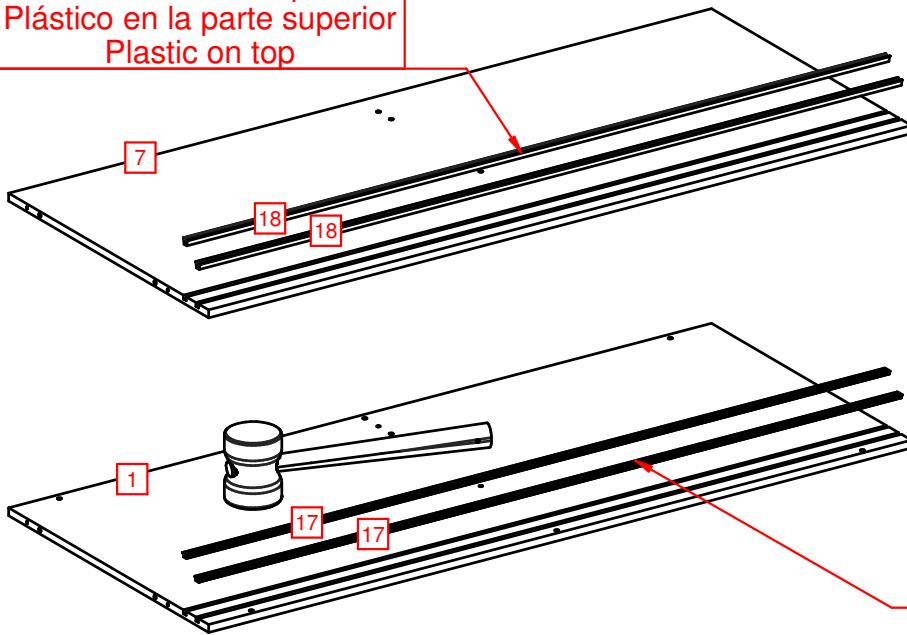

2

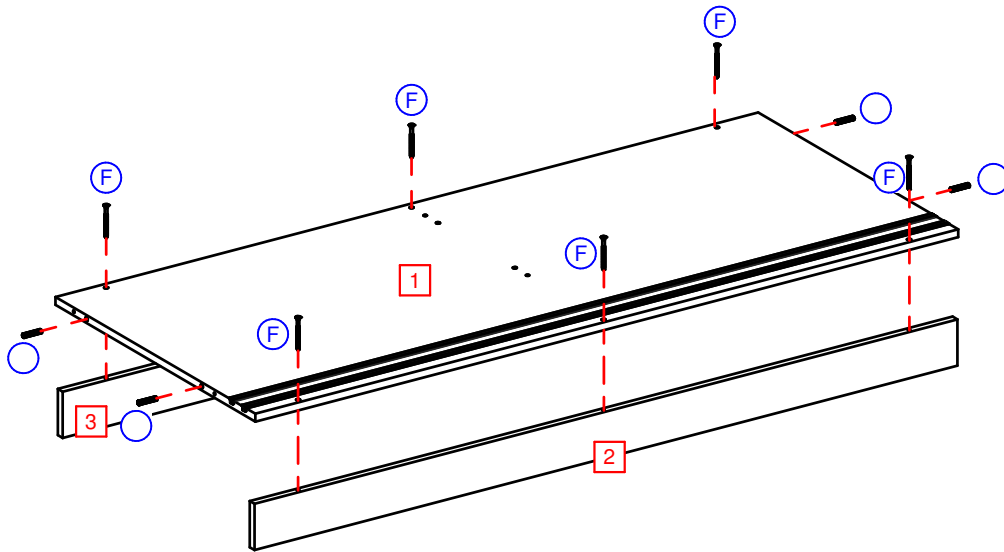

3

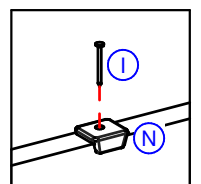
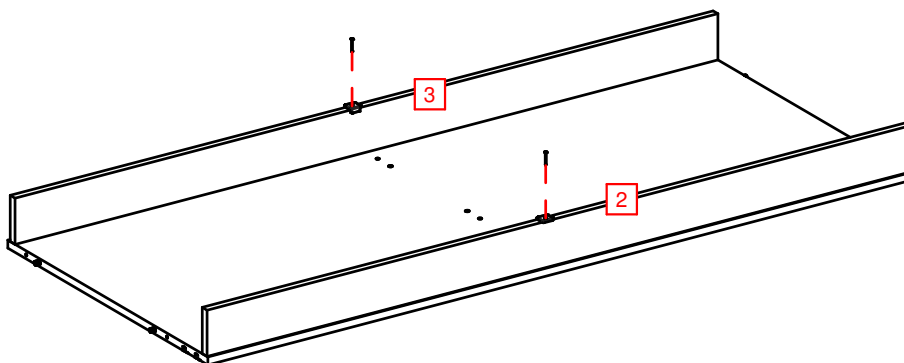

4

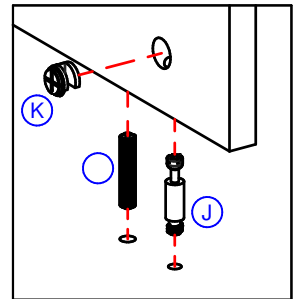
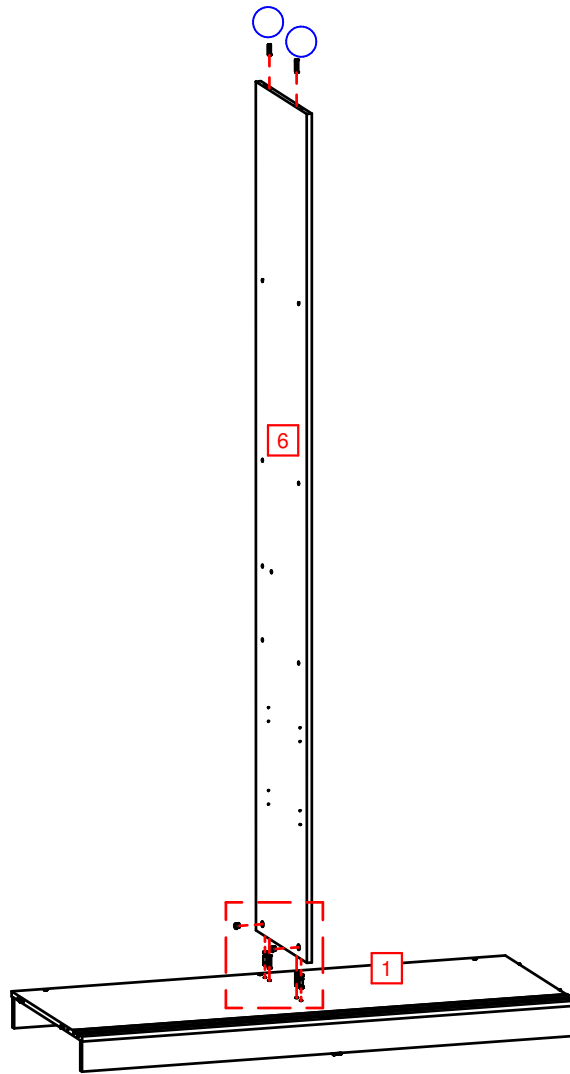

5

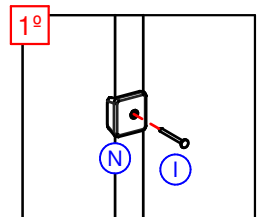
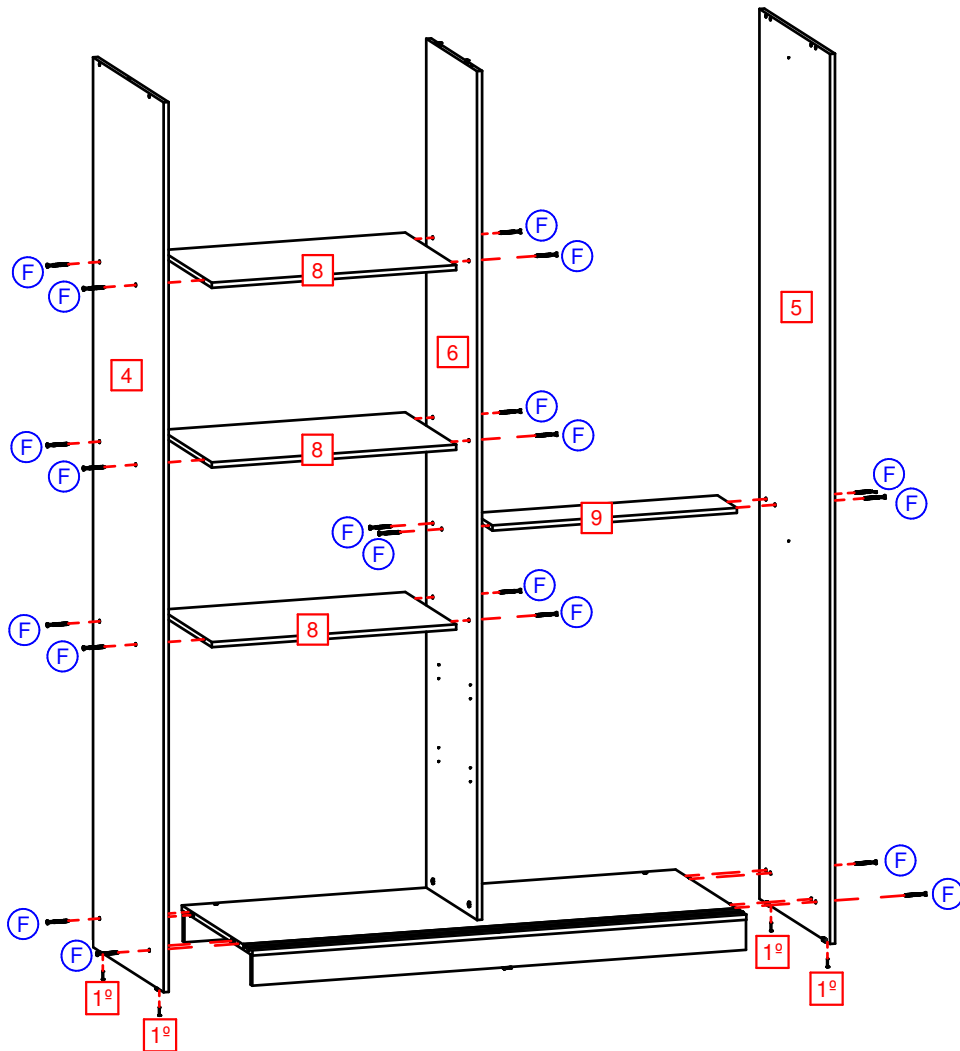

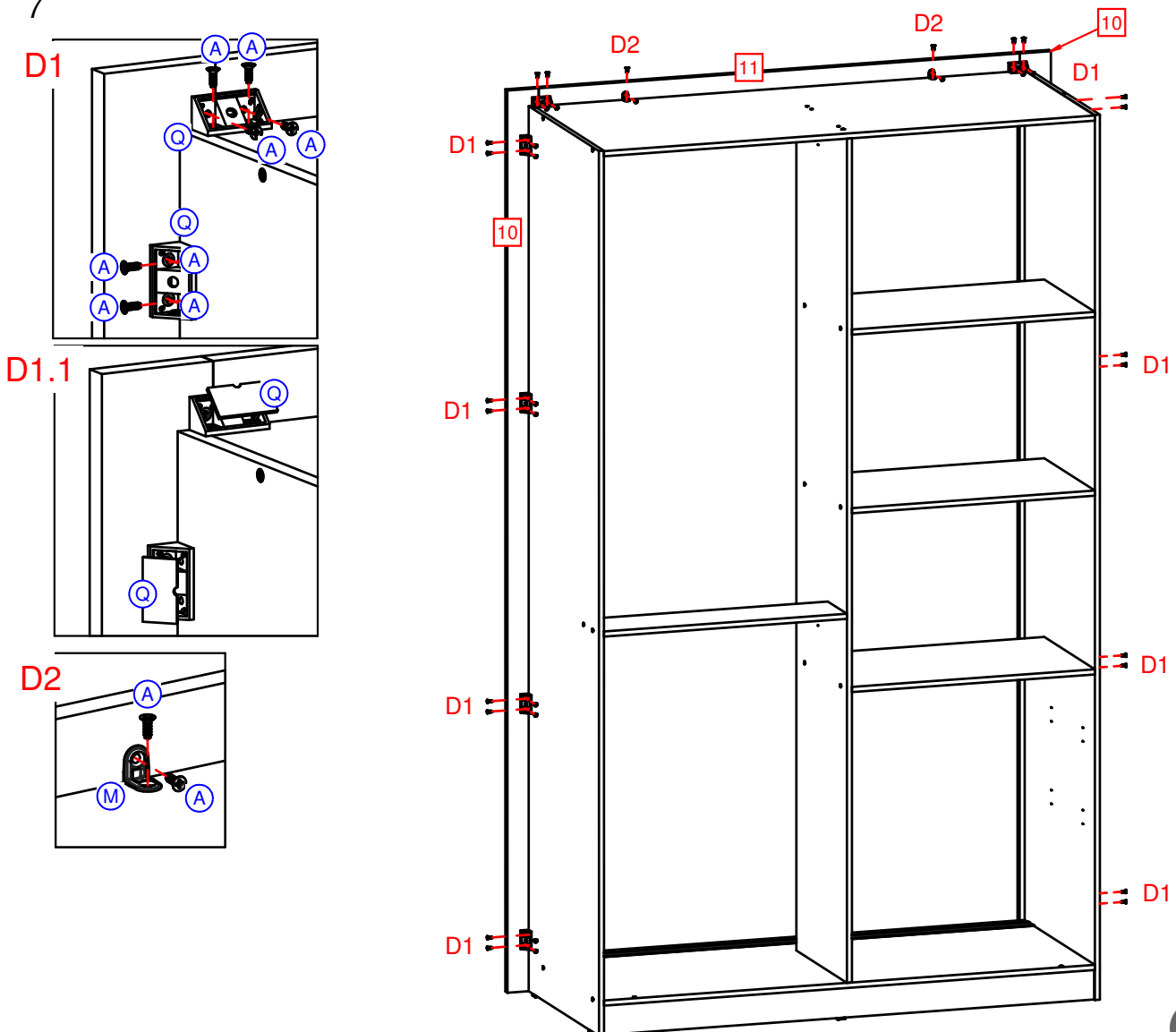
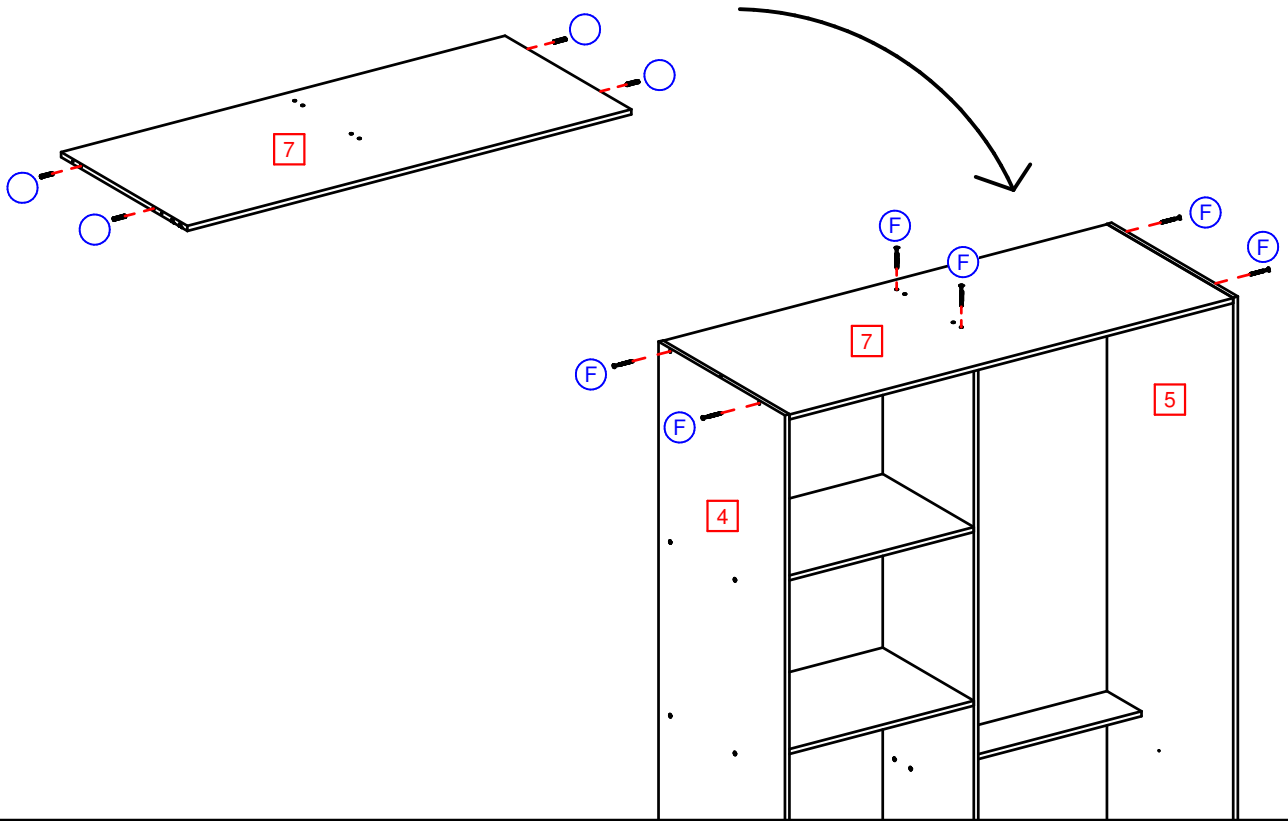

8

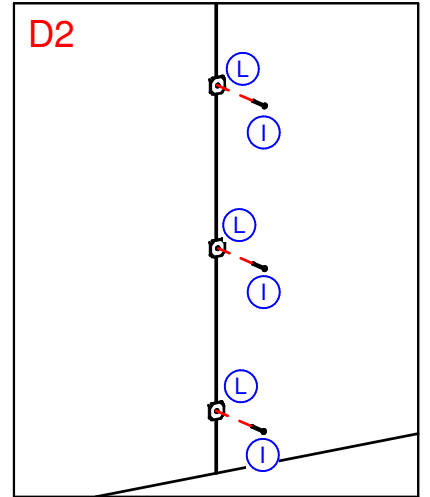
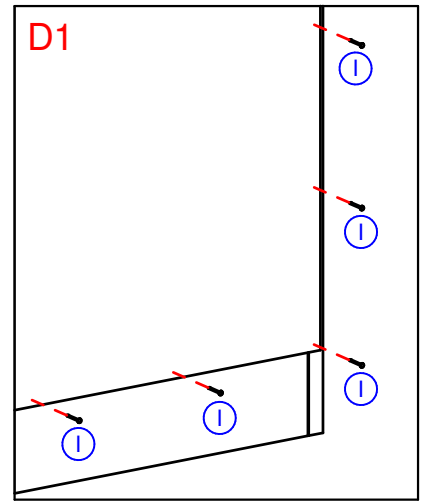
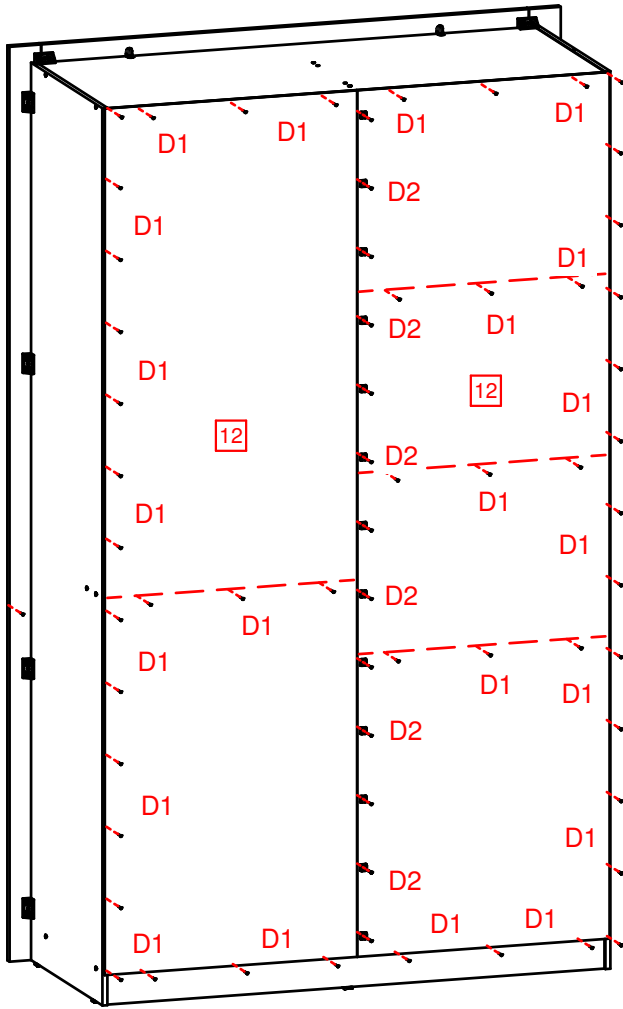

9

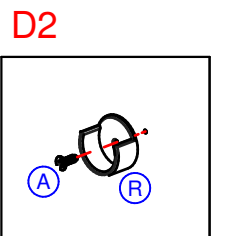
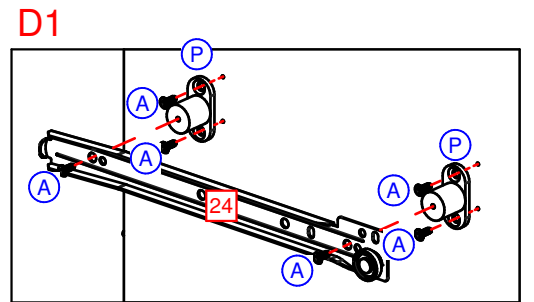
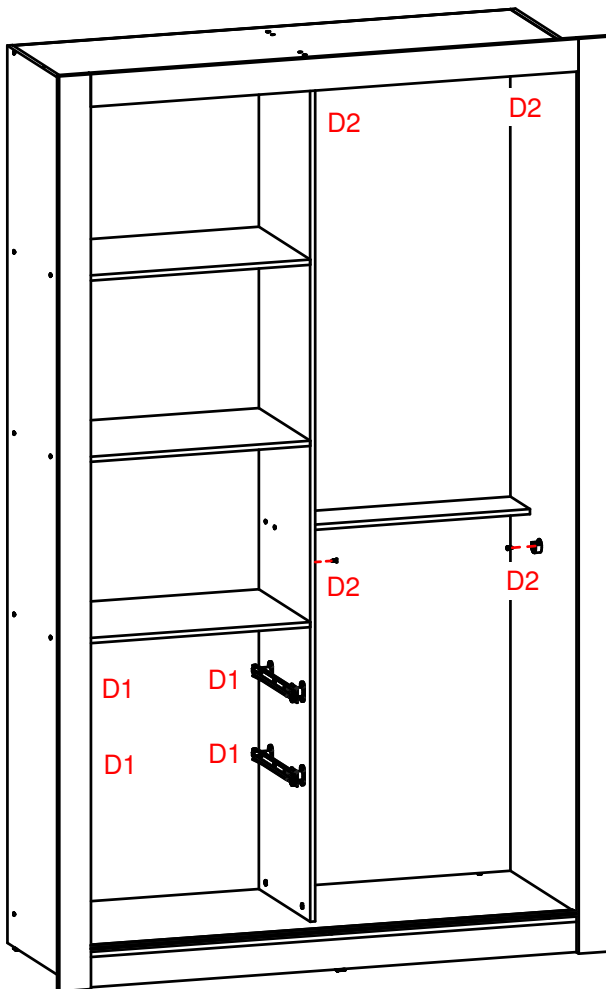

10-2x

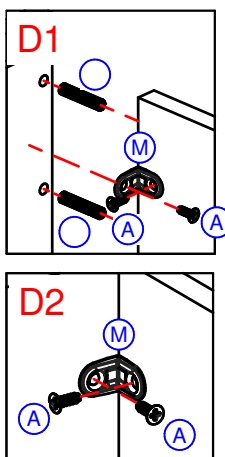
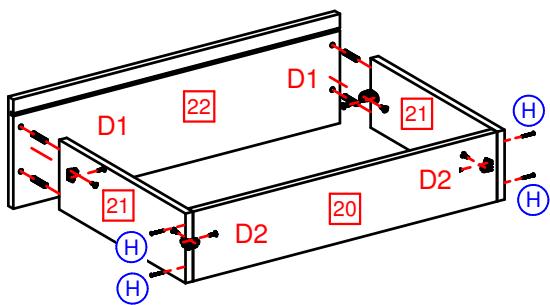

11-2x

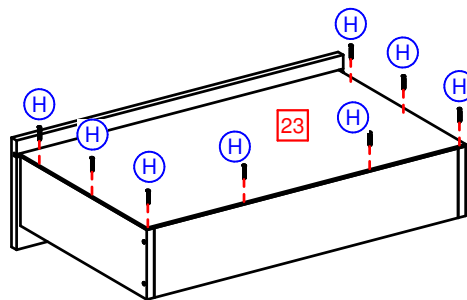

12-2x

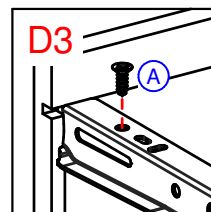
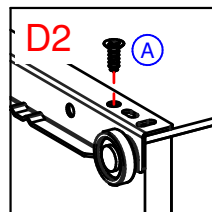
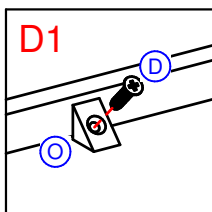
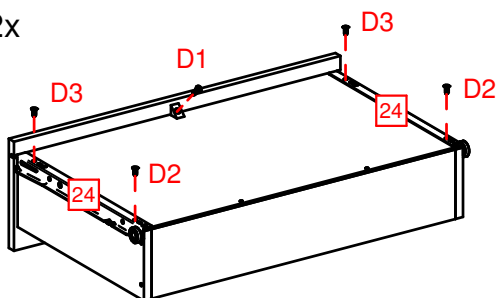

13

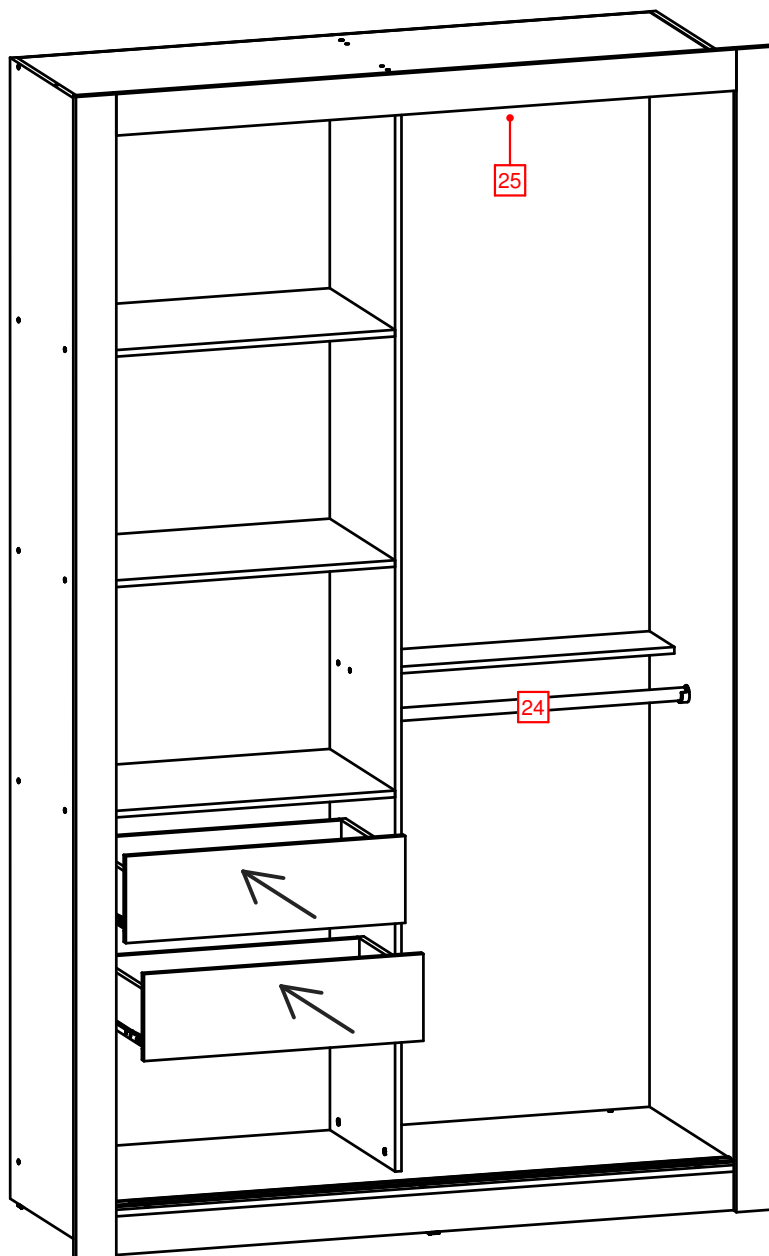



14

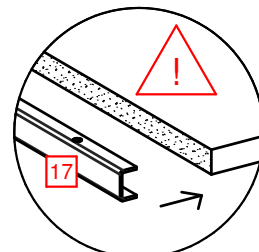
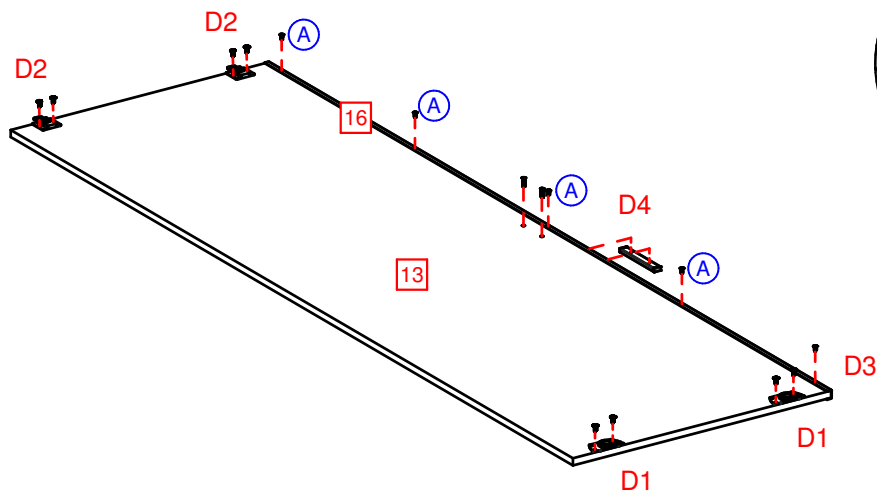
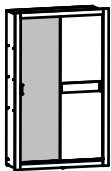

Fixar peça 17  
no lado sem borda!  
Fix part 17 on the side  
without a border!  
¡Fijar pieza 17 en el lado  
sin borde!

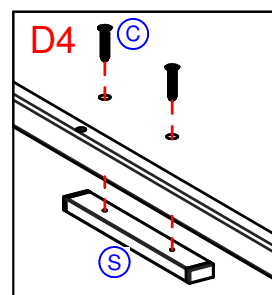
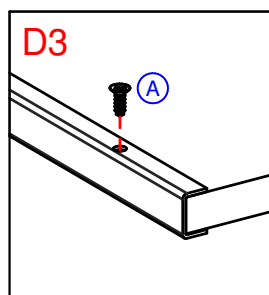
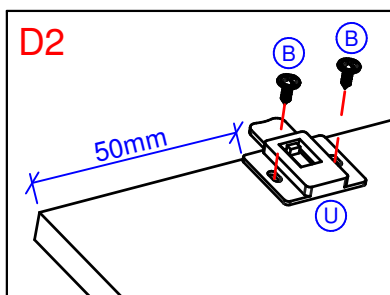
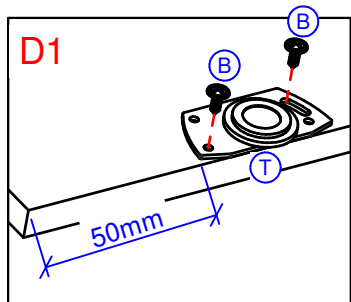

15

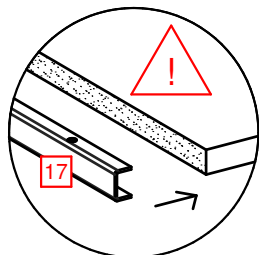
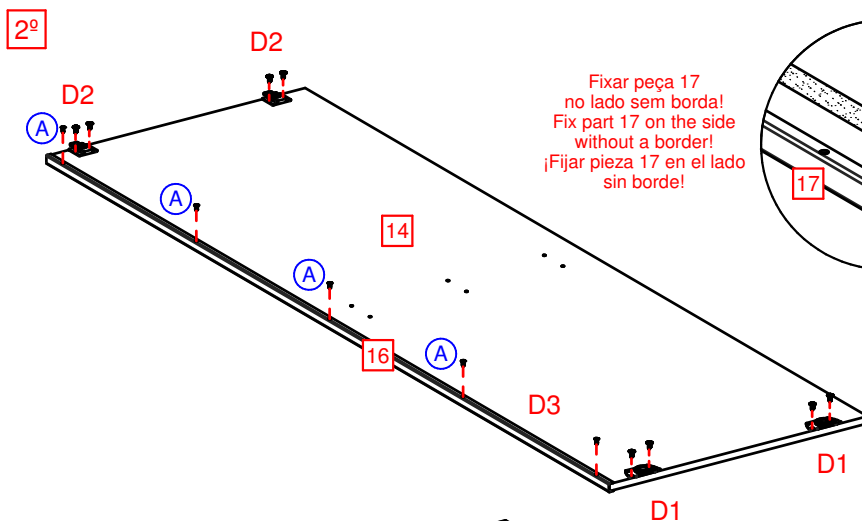
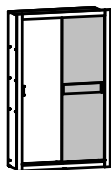

Fixar peça 17  
no lado sem borda!  
Fix part 17 on the side  
without a border!  
¡Fijar pieza 17 en el lado  
sin borde!

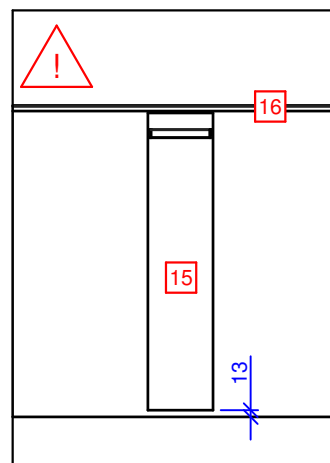
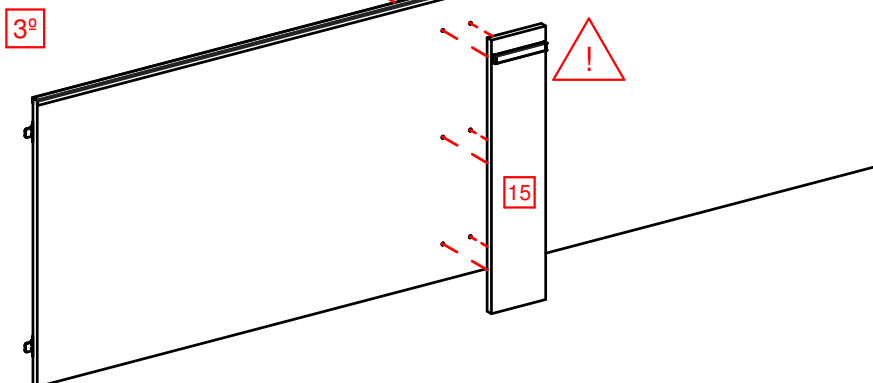
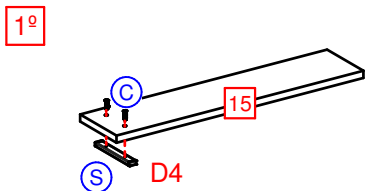

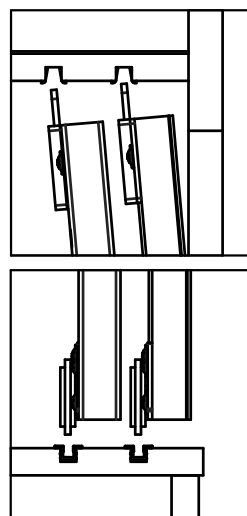
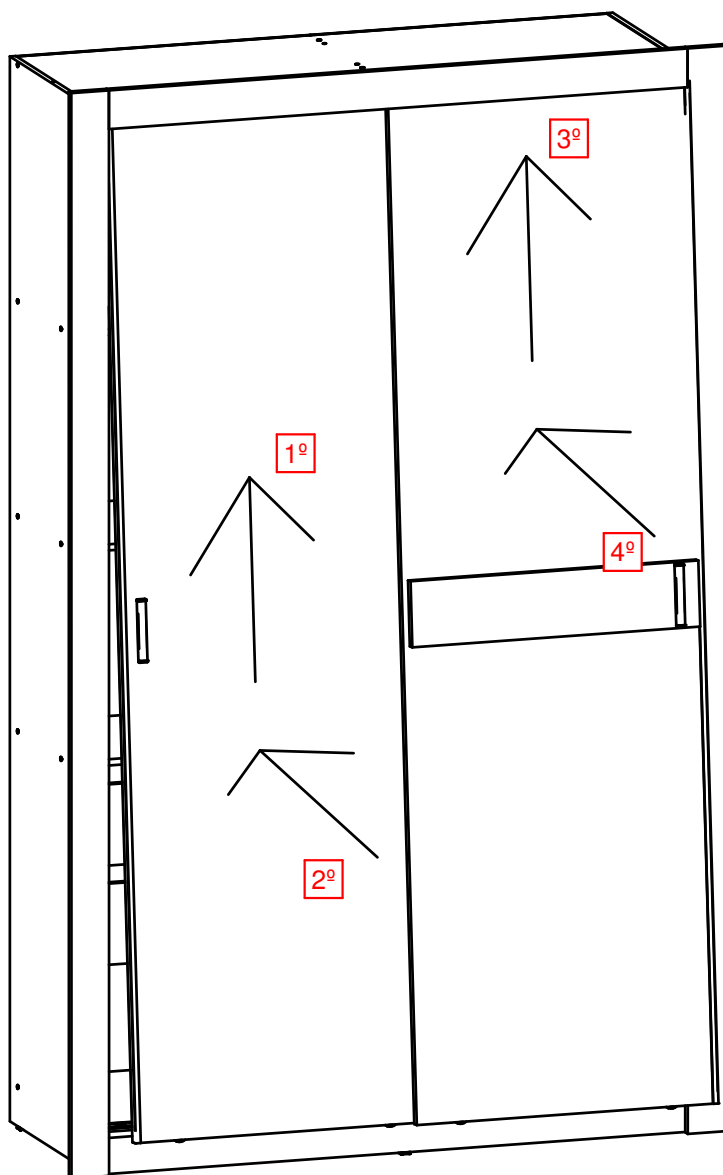

**Ajuste Puertas / Doors Adjustment / Regulagem Portas**

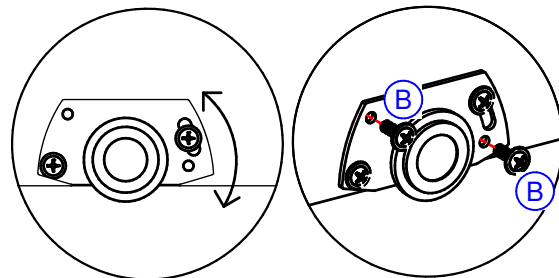

Poner dos batientes en las puertas deslizantes, según el detalle.

Please, put two door stops on sliding doors, as detail.

Colocar dois batentes nas portas de correr, conforme detalhe.

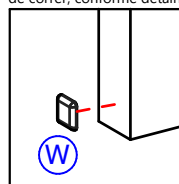

Poner tapa agujeros adhesivos, según el detalle.

Please, put adhesive hole covers, as per detail.

Colocar tapa furos adhesivos, conforme detalhe.

